

**Valves for Gases, Oils, Steam, Compressed Air, Water.** (For low pressure air valves, see Specifications 1004/1014.) All valves are for throttling control—not tight shutoff. (See Dimensions 1008A for weights and dimensions.)

Valve	Pipe size	Max inlet pressure (PSI)	Maximum Temp F.	Materials of Construction ■				
				Body	Core and Curtain	Shaft	Grease	Shaft Seal
1008A Valves	3/8", 1/2"	125	350	BRS	BRS-ENP	BRS-ENP	Litium #2	Viton
	3/4" thru 2"	125	350	DI	CRS-ENP	SST	Litium #2	Viton
	2-1/2" thru 6" •	125	350	DI	BRS-ENP	SST	Litium #2	Viton
1008A-S (steam)	3/8", 1/2"	125	350	BRS	BRS-ENP	BRS-ENP	Silicone compound	EP
	3/4" thru 2"	125	350	DI	CRS-ENP	SST	Silicone compound	EP
	2-1/2" thru 6" •	125	350	DI	BRS-ENP	SST	Silicone compound	EP
1010A-S (steam)	3/4" thru 3"	125	350	BRS	Monel	SST	Silicone compound	EP

Valves must be properly lubricated. See Sheet 1008A-3.

- 4" and 6" are flanged type, furnished with ductile iron companion flanges.
- Materials abbreviations: BRS = brass, CRS = cold rolled steel, DI = ductile iron, SST = stainless steel, ENP = electroless nickel plating.

**1015 COMMON SHAFT Valve Combinations – Air, Gas, and Oil** (See Sheet 1015 for dimensions.)

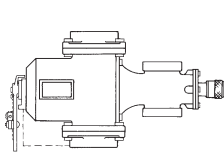

1015 common shaft combination 1004 Air and 1008A Gas

	3-B (1 1/2") or 4-B (2")		4-C (2") 5-C (2 1/2") or 6-C (3")		6-D (3") or 7-D (4")		8-E (6")			9-F (8")		
air valve												
gas valve	-0 (3/8")	-1 (1")	-1 (1")	-2 (1 1/4")	-3 (1 1/2")	-4 (2")	-4 (2")	-5 (2 1/2")	-6 (3")	-6 (3")	-7 (4")	-8 (6")
wt in lb	15	16	23	31	42	44	88	105	103	331	345	428

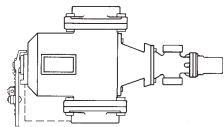

1015 common shaft combination 1004 Air and 1008A Oil

	3-B (1 1/2") or 4-B (2")		4-C (2") 5-C (2 1/2") or 6-C (3")		6-D (3") or 7-D (4")		8-E (6")			9-F (8")		
air valve												
oil valve	-02 (3/8")		-02 (3/8")		-01 (1/2")		-0 (3/4")			-0 (3/4")		
wt in lb		21		35		43		94			280	

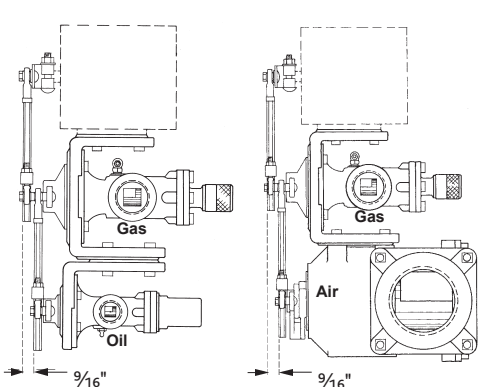

**1003 SIDE-BY-SIDE VALVE COMBINATIONS**  
 Several side-by-side valve combinations are available. Pictured on far left is a 1008AU Gas and 1008A Oil side-by-side combination. Next to it is a 1008AU Gas and 1004 Air side-by-side combination. 1008AU Oil and 1004 Air side-by-side combinations are also available.

**1018 THREE-WAY VALVE COMBINATIONS**  
 Three-way valve combinations are available for Air-Gas-Oil and Air-Oil-Steam. The two valves on the common shaft must be from the common shaft combinations listed above.

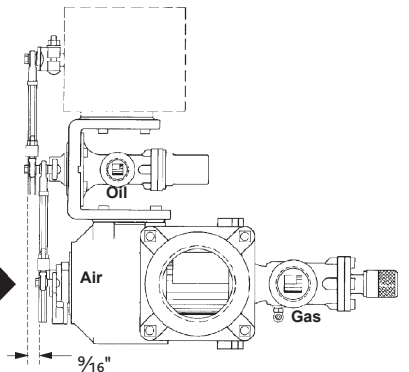

## SELECTION

Fluid	Pressure	Valve	Refer to
Air	0-3 psig 0-125 psig	1004, 1014 1008A	Specifications 1004/1014 Sheet 1008A-1 and example below
Gas, Oil Water	0-125 psig	1008A	Capacities 1008A Sheet 1008A-1 and example below
Steam (saturated)	0-125 psig	1008A-S 1010A-S	Capacities 1008A Sheet 1008A-1 and examples below

## SIZING

**Air, 3-125 psig.** Subtract desired high flow pressure drop from absolute upstream of the valve to get absolute pressure downstream of the valve. Divide this by upstream absolute pressure. If the result is 0.7 or more, refer to Chart A of Sheet 1008A-1. Multiply the desired maximum air flow, scfm, by the appropriate density correction factor from the inset on Chart A, and locate the intersection of lines corresponding to corrected flow and pressure drop. The first diagonal line above this point indicates the correct valve size. If the ratio of downstream absolute pressure to upstream absolute pressure is 0.69 or less, read the intersection, on Chart B, of lines corresponding to upstream absolute pressure and flow, scfm (**do not** multiply by the density correction factor). The first diagonal line above this point represents the correct size valve.

Example: Select a valve to control 1225 scfm air in a 35 psig line. Maximum pressure drop across the wide open valve should be 10 psi. Pressure downstream of the valve will be  $(35 - 10) = 25$  psig. Ratio of absolute pressures is  $(25 + 15)$

$\text{psia} \div (35 + 15) \text{ psia} = 0.8$ . Use Chart A. Density correction factor for 50 psia upstream pressure is 0.53 (from inset, Chart A). Corrected flow is  $1225 \text{ scfm} \times 0.53 = 650 \text{ cfm}$ . First diagonal line above intersection of 10 psi pressure drop and 650 cfm lines on Chart A represents a 2" valve.

**Gas, 2 psig and up.** Follow the same procedure as with 3-125 psig air, using Chart A for absolute pressure ratios of 0.7 and higher and Chart B for ratio of 0.69 or less. In either case, multiply flow, scfm, by the appropriate gas gravity correction factor from the two-line table across the top of the inset on Chart A.

**Steam (saturated), up to 125 psig.** (Specify "-S" model.) When ratio of downstream absolute pressure to upstream absolute pressure is 0.7 or greater, use same selection method as with 3-125 psig air, but select valve from Chart C. When pressure ratio is 0.69 or less, follow procedure for 3-125 psig air, but select valve from Chart D.

## HOW TO ORDER

Valve	Code for pipe size	Options	
1008A-__			Standard Valve
1008AU-__			Valve with optional U bracket (for side by side combo)
1010A-__			Brass and Monel construction (for steam or oxygen* service)
	-02		3/8"
	-01		1/2"
	-0		3/4"
	-1		1"
	-2		1 1/4"
	-3		1 1/2"
	-4		2"
	-5		2 1/2"
	-6		3"
	-7		4"
	-8		6"
		blank	no option
		-R	reverse acting
		-S	steam service
		-L	NEMA 4 low fire switch
		-LD	manual locking device
		-LDL	manual locking device and NEMA 4 low fire switch
		-C	Cleaned for oxygen service *see Bulletin 1010A-C/1008A-C

Examples: 1008A-3-R 1 1/2" adjustable port valve reverse acting  
 1008AU-4-LDL 2" adjustable port valve with U bracket manual locking device and low fire switch  
 1008A-8 6" adjustable port valve

\*See Bulletin 1010A-C/1008A-C for oxygen service.

**1020**

Designates any single valve/operator combination that Fives North American is to ship assembled, regardless of whether FNA sold the operator along with the valve or the customer supplied the operator for FNA to mount.

*Example:* 1020 Valve combination consisting of 1008A-4 Valve with B & L and M940 Operator mounted.

**1021**

Designates any single valve that Fives North American is to ship with bracket and linkage only assembled without an actuator.

**1003 Side-by-Side Valve Combinations** – Valve combinations are entered in the following order:

1. Fuel valve
2. Air valve or second fuel valve
3. Air valve
4. Bracket and linkage for customer's control motor, or operator that Fives North American is to supply and mount. Any other modifications of the linkage are also noted here.

The operator is normally mounted on the fuel valve, usually an adjustable port valve with "U" bracket.

	<u>Quantity</u>	<u>Part Number</u>	<u>Description</u>
<i>Example</i>	1	1003	Side-by-Side Valve Combination consisting of: 1008A-4 Valve w/ 1004-6-C Valve w/ B & L for M940

**1015 Common Shaft Valve Combinations** – Order write-up procedure:

**1015 - 04B3 - 02** Common Shaft Valve Combination with B & L and

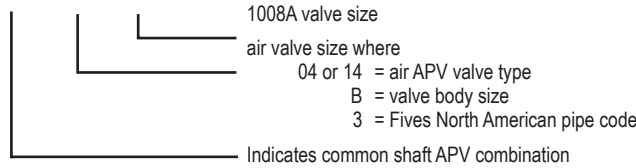

**1018 Three-Way Valve Combinations**

	<u>Quantity</u>	<u>Part Number</u>	<u>Description</u>
<i>Example</i>	1	1018	Three-Way Valve Combination consisting of: 1015 Common Shaft Valve Combination consisting of: 1008A-3 Valve w/ 1004-6-D Valve mounted side-by-side to 1008A-01 Valve w/ B & L for M940

**WARNING:** Situations dangerous to personnel and property may exist with the operation and maintenance of any combustion equipment. The presence of fuels, oxidants, hot and cold combustion products, hot surfaces, electrical power in control and ignition circuits, etc., are inherent with any combustion application. Parts of this product may exceed 160F in operation and present a contact hazard. Fives North American Combustion, Inc. urges compliance with National Safety Standards and insurance Underwriters recommendations, and care in operation.