

The 7345 High Pressure Regulators are self operated, spring loaded regulators that reduce high gas supply pressures to practical use levels. The outlet pressure ranges are higher for the type "H" regulators. 7345 Regulators include an internal relief valve for limited over pressure protection (see Operation on Page 3). They can be used with various gases including natural gas, propane and air.



7345A-01-H2

7345A-01-B, 7345A-01-H1, and 7345A-01-M1

7345-02 and 7345-02-H

SPECIFICATIONS

**7345A-01-B, 7345A-01-H1,
7345A-01-H2, and 7345A-01-M1**

Body Size: 1/2" x 1/2" NPT screwed
Maximum Operating Inlet Pressure:
 250 psig for 7345A-01-H1
 125 psig for 7345A-01-B and 7345A-01-M1
 80 psig for 7345A-01-H2
Maximum Outlet Pressure: Emergency: 20 psig
 Maximum outlet pressure to avoid internal part damage:
 3 psi above outlet pressure setting
Outlet Pressure Ranges: See Table 1
Regulating Capacities: See Table 1
Temperature Range:
 -20 to 160 F
 -20 to 150 F for 7345A-01-H2
Spring Case Vent Connection: 3/4" NPT
Approximate Weight: 1.75 pounds
Dimensions: See Page 2
Materials:
Body: aluminum
 cast iron for 7345A-01-H2
Spring Case: aluminum
Diaphragm: dacron fabric reinforced nitrile
Trim Parts: stainless steel, plated steel
 plated steel for 7345A-01-H2

7345-02 and 7345-02-H

Body Size: 1/4" NPT screwed inlet x 3/8" NPT screwed outlet
Maximum Operating Inlet Pressure: 250 psig
Maximum Outlet Pressure: Emergency: 20 psig
 Maximum outlet pressure to avoid internal part damage:
 3 psi above outlet pressure setting
Outlet Pressure Ranges: See Table 1
Regulating Capacities: See Table 1
Temperature Range: -20 F to 160 F
Spring Case Vent: 1/8" NPT with removable screen
Approximate Weight: 1.3 pounds
Dimensions: See Page 2
Materials:
Body/Lower Casing: zinc
Spring Case: zinc
Diaphragm: natural rubber
Trim Parts: stainless steel and cadmium plated steel

TABLE 1. Outlet Pressures and Capacities for 7345 Regulators

Regulator designation	pipe size inches	outlet pressure range	offset	Capacities in cfh of natural gas (0.6 sp gr) with inlet pressure in psi									
				2	5	10	25	50	75	100	150	200	250
7345-02	1/4 inlet x 3/8 outlet	9.25"wc to 13"wc	1"wc	—	—	75	140	155	155	155	155	155	155
7345A-01-B	1/2 inlet x 1/2 outlet	9"wc to 13"wc	2"wc	—	274	401	623	708	676	721	—	—	—
7345-02-H	1/4 inlet x 3/8 outlet	0.5 psi to 2.7 psi	10% to 20%	—	—	50	85	105	130	145	200	260	300
7345A-01-H1	1/2 inlet x 1/2 outlet	2.25 psi to 5.5 psi	10%	—	—	525	950	1500	1600	2100	2625	2850	150
7345A-01-H2	1/2 inlet x 1/2 outlet	1-2 psi	10%	60	125	200	450	550	650	—	—	—	—
7345A-01-M1	1/2 inlet x 1/2 outlet	16"wc to 35"wc	10%	—	174	337	533	679	756	762	—	—	—

DIMENSIONS
inches

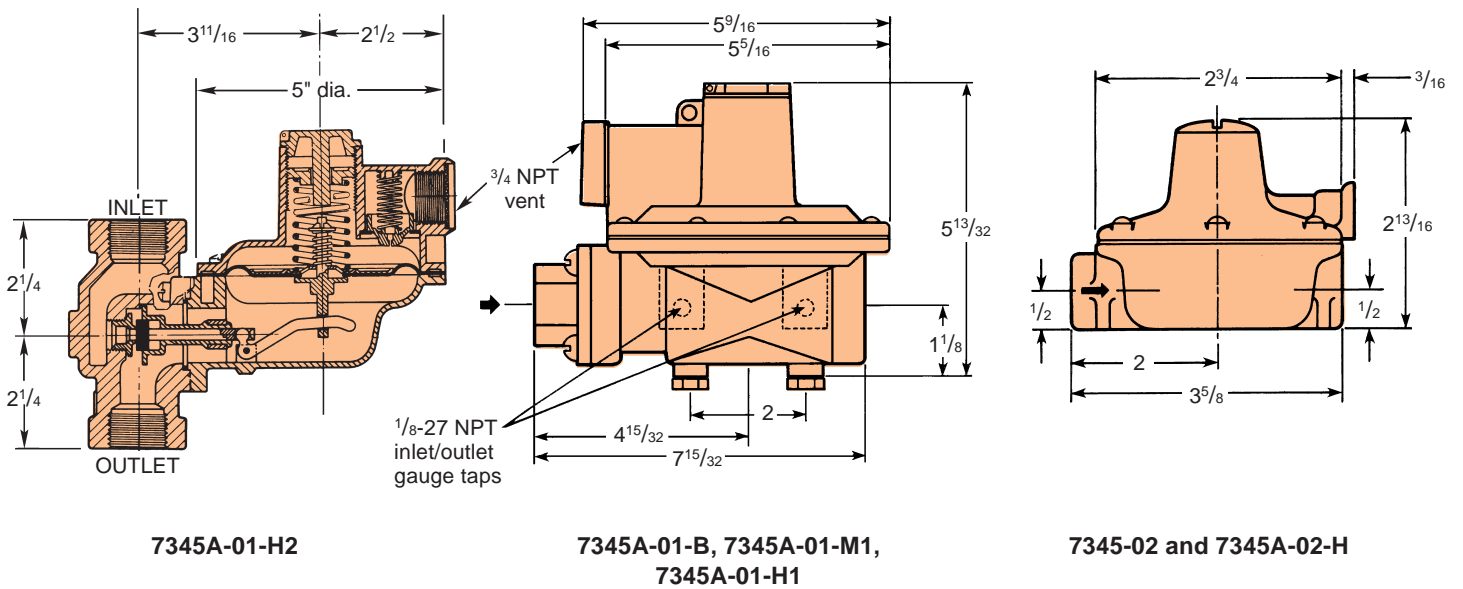

DIMENSIONS SHOWN ARE SUBJECT TO CHANGE. PLEASE OBTAIN CERTIFIED PRINTS FROM FIVES NORTH AMERICAN COMBUSTION, INC. IF SPACE LIMITATIONS OR OTHER CONSIDERATIONS MAKE EXACT DIMENSION(S) CRITICAL.

OPERATION

7345 Regulators have an outlet pressure rating lower than the inlet pressure rating. An internal relief valve protects against excessive pressure buildup resulting from failure of the valve to seat properly due to worn internals or foreign material on the orifice.

The internal relief capacity is adequate only for relieving minor buildup which may be caused by chips or dirt blocking the seat partly open. The capacity of the internal relief is not sufficient to protect downstream equipment from overpressurization if the regulator fails open. Appropriate overpressure equipment should be installed to protect downstream equipment.

The outlet pressure of each 7345 Regulator is factory set at the mid-range of the control spring. If it is necessary to change outlet pressure, remove the closing cap and turn the adjusting screw counterclockwise to decrease outlet pressure or clockwise to increase outlet pressure. Adjustments must be made with gas flowing. A pressure gauge is needed to determine outlet setting. Always replace the closing cap after adjustment.

INSTALLATION

Before installing the regulator, check for damage which might have occurred during shipment. Also, check for and remove any dirt or foreign matter which may have accumulated in the regulator body or pipeline. Apply pipe compound to the male threads of the pipe and use approved piping procedures when installing the regulator.

All 7345 Regulators may be installed in any position, however, make sure gas flow through the regulator is in the same direction as the arrow on the body. "Inlet" and "Outlet" connections are clearly marked.

The spring case vent should be pointed down on outside installations. For indoor installations or if gas escaping through the internal relief valve could constitute a hazard, the tapped vent should be piped to outdoors where escaping gas will not be hazardous. If the vent will be piped to another location, obstruction-free tubing should be used and a screened vent should be installed on the end of the vent pipe. Use pipe or tubing equal in size to the regulator's vent for the vent line. On all installations, the vent or end of the vent pipe must be protected from corrosive chemicals, debris, weather, condensation, insects, or anything else that might clog or enter the spring case.

NOTE: Refer to the *National Fuel Gas Code (ANSI Z223.1)* for complete installation requirements.

WARNING: Situations dangerous to personnel and property may exist with the operation and maintenance of a combustion equipment. The presence of fuels, oxidants, hot and cold combustion products, hot surfaces, electrical power in control and ignition circuits, etc., are inherent with any combustion application. Parts of this product may exceed 160F in operation and present a contact hazard. Fives North American urges compliance with National Safety Standards and insurance Underwriters recommendations, and care in operation.

Fives North American Combustion, Inc., 4455 East 71st Street, Cleveland, OH 44105 USA, Phone 216.271.6000
Fax 216.641.7852 email: fna.sales@fivesgroup.com • www.fivesgroup.com/fivesna