

7335 Regulators reduce gas supply pressures (40 or 60 psi maximum) to discharge pressures ranging from 32 psi to atmospheric. Flow capacities on natural gas range from 9000 to 200 000 cfh. Regulators are suitable for natural gas, propane, LP gas, or air. Consult North American for coke gas applications.

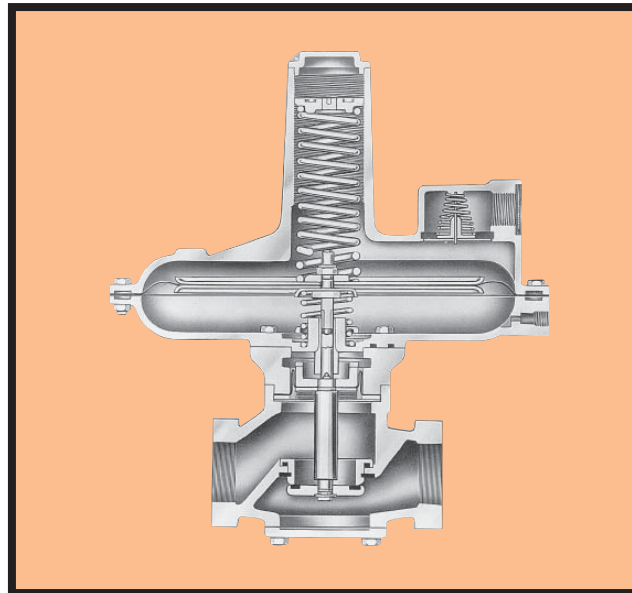

Ratio Regulator Service

7335-0 Regulators that can be set for zero outlet pressures can be used as cross-connected ratio regulators. The regulator 1" vent is connected to the combustion air line with 1/2" pipe or 5/8", or 3/4" OD tubing (bushing up to 1" at the regulator).

Installation

Regulators should be installed in horizontal clean pipe with unions on each side to facilitate removal for servicing. Apply pipe compound to threaded pipe ends only.

If 7335 Regulator is used with other downstream regulators, they should be separated by at least 15 pipe diameters to avoid interaction.

At higher capacities, it is necessary to increase discharge pipe size (use a reducing coupling). Use Figure 4 to select proper discharge pipe size.

Figure 3 is a guide for piping and installation. An external line is required to sense downstream pressure and provide control feedback to regulator. When necessary, an orifice is added to this line to dampen pulsation. Correct size is largest orifice that effectively controls pulsation.

Relief Valves

An external 7377 Relief Valve must be ordered with each 7335 Regulator. When a downstream shutoff valve is used, relief valve must be mounted between regulator and valve. See Table 5 on page 4 for Relief Valves sizes.

Regulators with discharge pressures of 16 psi or less have a relief valve set to start relieving at 2.5 psi. Regulators with 16-32 psi discharge pressure are furnished with relief valve set at 5 psi.

Construction

Regulators are single port with roll-balancing diaphragms for long valve travel.

Materials

- Body—cast iron
- Diaphragm cases—aluminum
- Diaphragms—Buna-N or nylon
- Trim—zinc, steel, stainless steel

Regulator springs can be adjusted with screwdriver or standard socket wrench. Field interchangeable springs on 7335-1, -3, and -4 Regulators allow varying discharge pressure range including (zero) atmospheric service. Table 5 lists spring selections.

Table 1. Natural gas capacities, in cfh.

Regulator designation	Outlet pressure, osi	Outlet press. droop* osi	Inlet pressure, psi						Maximum supply press., psi
			5	10	15	25	40	50	
7335-1-0	0	0.6	11 200	14 500	17 300	23 200	32 000	38 000	60
7335-1-8	8	1.2	9 900	13 700	16 500	22 700	31 200	37 700	
7335-1-16	16	1.8	9 800	13 500	16 000	22 500	31 000	37 000	
7335-1-32	32	4	9 000	12 200	15 000	21 400	30 100	35 500	
7335-3-0	0	0.6	19 500	30 000	37 000	50 000	68 000	80 000	60
7335-3-8	8	1.2	18 500	28 000	36 200	49 000	67 000	79 000	
7335-3-16	16	1.8	18 000	27 500	35 700	48 000	66 500	78 000	
7335-3-32	32	4	16 400	25 100	34 000	46 000	64 000	75 000	
7335-4-0	0	0.6	35 000	52 000	68 000	90 000	125 000	150 000	60
7335-4-8	8	1.2	34 500	51 000	67 500	89 000	124 000	148 000	
7335-4-16	16	1.8	34 000	50 000	66 000	88 500	121 500	146 000	
7335-4-32	32	4	30 000	49 000	64 500	84 500	118 000	143 000	
7335-6-A0	0	0.6	80 000	125 000	145 000	190 000	260 000	—	40
7335-6-A8	8	1.2	78 000	120 000	145 000	190 000	260 000	—	
7335-6-16	16	1.8	75 000	115 000	140 000	190 000	260 000	—	
7335-6-32	32	4	65 000	100 000	135 000	183 000	200 000	—	

Corrections for Gravity

For gases with specific gravity other than 0.6, apply correction factor from Table 2. Divide desired flow by factor to get equivalent flow of natural gas. Select regulator with appropriate capacity and discharge pressure.

Multiply regulator's natural gas capacity by gravity factor to get its capacity with different gas.

Table 2. Gravity corrections

Gas gravity	Factor	Example Gas
0.4	1.22	Coke Oven
0.6	1.00	Natural
1.0	0.774	—
1.5	0.632	Propane
2.0	0.547	Butane

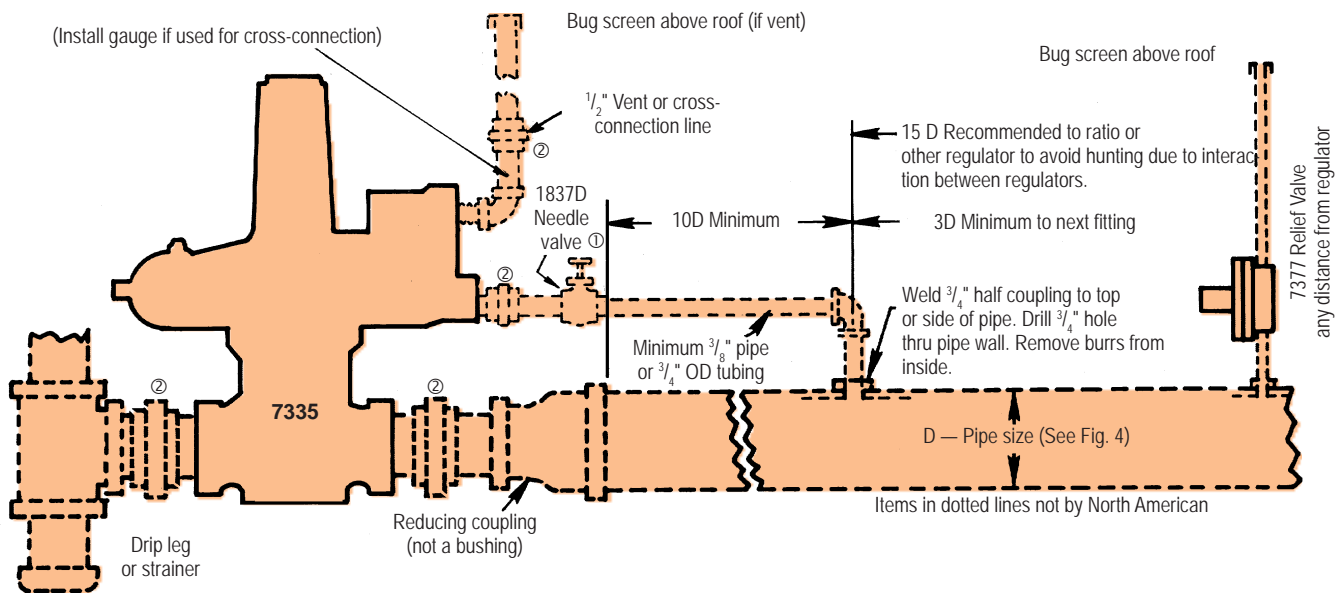

Figure 3. Detail of regulator and relief valve installation.

* When regulator flow is at capacity shown, discharge pressure will be lowered from setpoint by approximately 10%. The "Pressure Droop" should be taken into account when selecting a regulator and spring range.

① When necessary to dampen pulsation, use a fixed orifice, or an 1837D Needle Valve with internal bypass (see Page 4), which allows on-line "tuning out" of outlet pressure pulsation.

② Use pipe unions to simplify regulator removal for repair or replacement.

Figure 4a. Quick approximation for downstream pipe size.

	Outlet Pressure			
	Zero	8 osi	16 osi	32 osi
0	2 1/2"	2 1/2"	2"	2"
10 000	3"	3"	3"	3"
20 000	4"	4"	4"	4"
30 000	6"	6"	6"	6"
40 000	8"	8"	8"	8"
50 000	10"	10"	10"	10"
60 000	10"	10"	10"	10"
70 000	10"	10"	10"	10"
80 000	10"	10"	10"	10"
90 000	10"	10"	10"	10"
100 000	10"	10"	10"	10"
150 000	10"	10"	10"	10"
200 000	10"	10"	10"	10"

Accurate calculation for downstream pipe size per Figure 4b.

1. Determine maximum allowable pressure drop (ΔP_D) downstream of 7335. $\Delta P_D = 7335$ outlet pressure minus pressure required at inlet of gas flow control device.
2. Start with downstream pipe size indicated in Figure 4a. Using that pipe size, determine equivalent length (L_D) of pipe and fittings between 7335 and gas flow control device. (For equivalent lengths of valves and fittings, see Table 5.22 in North American COMBUSTION HANDBOOK, or use North American Pipe Rule.)
3. Correct $\Delta P_D \div L_D$ to 100 equivalent feet of pipe: $\Delta P_D \div L_D / 100 = \Delta P_{100}$.
4. On Figure 4b, locate maximum cfh natural gas pipe must carry, read across to (diagonal) pipe size line, then down to pressure drop per 100 equivalent feet of pipe. If result is less than ΔP_{100} , pipe is sufficient. If result exceeds ΔP_{100} pipe is undersized--repeat procedure for larger sizes until a satisfactory pressure drop results.

Figure 4b. Accurate calculation for downstream pipe size.

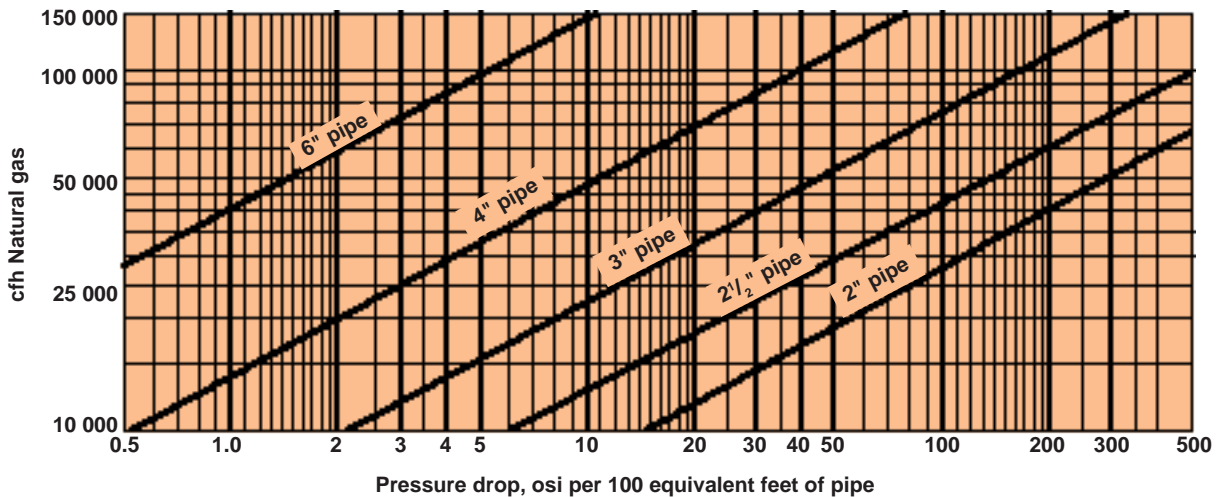
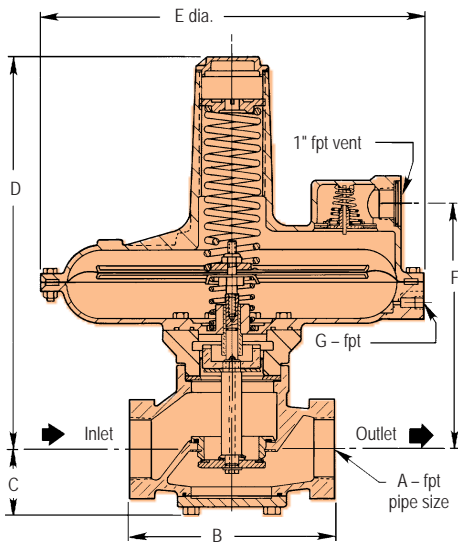

Table 5. Spring identification

Regulator designation	Spring ^③		(Atmospheric) -0.6 to +0.7 osi	Outlet pressure range					Companion relief valve
	R number	Color		3.5 to 8 osi	8 to 16 osi	16 to 32 osi	24 to 48 osi		
7335-1-0 R690-5507	R690-5510 Black-Red	Red-Black	•						7377-1-2
7335-1-8	R690-5511	Green-Black		•					7377-1-2
7335-1-16	R690-5514	Green			•				7377-1-2
7335-1-32	R690-5513	Orange				•			7377-1-5
7335-1-48	R690-5518	Cadmium					•		7377-1-5
7335-3-0	R690-5510 R690-5508	Red-Black Black	•						7377-1-2
7335-3-8	R690-5514	Green		•					7377-1-2
7335-3-16	R690-5513	Orange			•				7377-1-2
7335-3-32	R690-5515	Black				•			7377-1-5
7335-3-48	R690-5518	Cadmium					•		7377-1-5
7335-4-0	R690-5510 R690-5508	Red-Black Black	•						7377-1-2
7335-4-8	R690-5514	Green		•					7377-1-2
7335-4-16	R690-5513	Orange			•				7377-1-2
7335-4-32	R690-5515	Black				•			7377-1-5
7335-4-48	R690-5518	Cadmium					•		7377-1-5
7335-6-A0	R690-5509 ^④ †	Black	•						7377-1-2
7335-6-A8	R690-5516†	Green		•					7377-1-2
7335-6-A16	R690-5517†	Orange			•				7377-1-2
7335-6-32	R690-5515†	Black				•			7377-1-5
7335-6-48	R690-5518	Cadmium					•		7377-1-5

- ③ Where two springs are listed, first spring is main, second is counterspring.
- ④ 7335-6-A0 uses a reversed main spring, no counterspring.
- † This is only spring suitable for this regulator.
- ‡ These springs will only fit -6-A regulators.



Regulator designation	Dimensions in inches							Wt, lb
	A	B	C	D	E	F	G	
7335-1	1	5 ³ / ₄	1 ¹ / ₈	13 ⁹ / ₁₆	10 ³ / ₁₆	8	1 ¹ / ₄	25
7335-3	1 ¹ / ₂	7 ¹ / ₂	2 ³ / ₈	14 ¹ / ₈	14	8 ³ / ₄	1 ¹ / ₄	40
7335-4	2	7 ¹ / ₂	2 ³ / ₈	14 ¹ / ₈	14	8 ³ / ₄	1 ¹ / ₄	40
7335-6-A	3	11 ³ / ₄	3 ³ / ₁₆	19	18	10 ⁵ / ₁₆	1 ¹ / ₂	90
7335-6	3	11 ³ / ₄	3 ³ / ₁₆	15 ¹ / ₂	14	10 ⁹ / ₁₆	1 ¹ / ₄	75

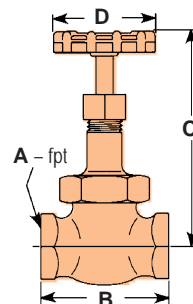

1837D Needle Valve with internal bypass:
A modified 1837 Valve in which a 5/64" bypass hole has been drilled (making tight shutoff impossible).

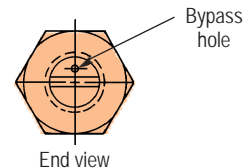

Dimensions in inches
Needle valves with fixed orifice bypass

Designation	A Pipe Size	B	C	D	Wt, lb
1837D-02	3/8	1 ¹³ / ₁₆	2 ³ / ₄	1 ³ / ₄	1/2
1837D-01	1/2	2 ¹ / ₁₆	3 ¹ / ₈	2 ¹ / ₁₆	3/4
1837D-0	3/4	2 ⁵ / ₁₆	4	2 ⁹ / ₁₆	1

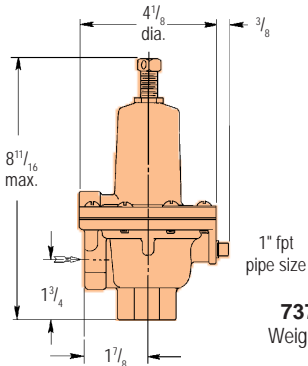

Relief Valves
Dimensions in inches

Note: If the upstream regulator is capable of a maximum flow greater than 87,000 scfh, contact North American Mfg. Co. for appropriate relief valve size.

7377-1
Weight: 4 lb

DIMENSIONS SHOWN ARE SUBJECT TO CHANGE. PLEASE OBTAIN CERTIFIED PRINTS FROM FIVES NORTH AMERICAN COMBUSTION, INC. IF SPACE LIMITATIONS OR OTHER CONSIDERATIONS MAKE EXACT DIMENSION(S) CRITICAL.

WARNING: Situations dangerous to personnel and property may exist with the operation and maintenance of an combustion equipment. The presence of fuels, oxidants, hot and cold combustion products, hot surfaces, electrical power in control and ignition circuits, etc., are inherent with any combustion application. Parts of this product may exceed 160F in operation and present a contact hazard. Fives North American urges compliance with National Safety Standards and insurance Underwriters recommendations, and care in operation.

Fives North American Combustion, Inc., 4455 East 71st Street, Cleveland, OH 44105 USA, Phone 216.271.6000
Fax 216.641.7852 email: fna.sales@fivesgroup.com • www.fivesgroup.com/fivesna