

Ref: Bulletin 7218

February 1989

7219 Regulators are modified 7218 Regulators with provision for remote downstream pressure sensing. The 7219SS includes a 3-way solenoid assembly to add tight shutoff control to the ratioing function.

Maximum inlet pressure: 2 psi service (4 psi shock).
 Maximum ambient temperature: 180 F (300 F for 7219V).

7219

The standard 7219 is used for one or more of the following reasons:

1. for greater capacity than can be realized through a 7218 with its 16 osi pressure drop limitation, and/or
2. for more accurate downstream pressure sensing than the 7218 allows with its internal pressure sensing tube, and/or
3. to sense downstream pressure at a point closer to burner or mixer: In some applications, this allows more accurate air/fuel ratioing.

The downstream pressure sensing connection is made in the field. For higher capacities, enlarged outlet pipe is required; and the pressure sensing connection must be made in this pipe (see minimum distances on back of this sheet).

7219SS

A factory-piped 3-way solenoid valve governs a 7219SS Regulator:

When energized, downstream gas pressure is sensed in the upper diaphragm case and the regulator controls air/fuel ratio like a standard 7219.

When solenoid is de-energized, upstream gas pressure is applied to the diaphragm, causing tight shutoff of the regulator.

The tight shutoff function is for control purposes only. It is not designed or approved for safety shutoff or long term system shutdown: Use separate automatic shutoff and manual cocks or valves, respectively, for these functions.

Table 1. CAPACITIES
cfh
with 2 osi drop through regulator

Regulator designation	Gas gravity			
	0.4	0.6	1.5	2.0
7219-0	300	250	150	135
7219-1	500	400	250	225
7219-2	1000	800	500	450
7219-3	1500	1200	775	675
7219-4	3000	2400	1500	1350
7219-5	5000	4000	2500	2250
7219-6	7350	6000	3800	3330
7219-7	13400	11000	7000	6000

Table 2. FACTORS
for capacities at other pressure drops

Pressure drop, osi	factor	Pressure drop, osi	factor
1	0.707	10	2.24
2	1.00	14	2.65
6	1.73	18	3.00

For higher drops, determine capacity using square root law:

$$\frac{cfh_1}{cfh_2} = \sqrt{\frac{\Delta P_1}{\Delta P_2}} \text{ e.g. for 22 osi drop across 7219-4:}$$

$$\frac{\text{cfh at 22 osi drop}}{2400 \text{ (cfh at 2 osi drop)}} = \sqrt{\frac{22}{2}}$$

$$\text{cfh at 22 osi drop} = 2400 \times \sqrt{\frac{22}{2}} = 7960 \text{ cfh.}$$

REGULATOR SELECTION

To size a regulator, determine required cfh of gas and pressure drop available at high fire. Divide required cfh by Table 2 factor for available pressure drop. Select smallest regulator with Table 1 (2 osi) capacity above this adjusted capacity.

EXAMPLES

A nozzle-mix system requires 900 cfh of natural gas. Gas inlet pressure is 12 osi; maximum air pressure at the burner is 8 osi.

When cross-connected, outlet gas pressure is 8 osi at high fire; pressure drop across regulator is 12 - 8 = 4 osi. Table 2 factor for 4 osi is 1.41; 900 cfh ÷ 1.41 = 638 cfh. In the 0.6 sp gr column of Table 1, select a 7219-2 Regulator (rated at 800 cfh).

If air pressure at the burner was 16 osi but available gas pressure was still only 12 osi, a bleeder would be required in the cross connection. For **minimum bleed**, select regulator for required cfh directly from Table 1 (2 osi) capacities; then bleed cross-connected air impulse at high fire from 16 osi to 10 osi (12 osi available gas pressure minus 2 osi drop through regulator). For the required 900 cfh in this example, select a 7219-3 from Table 1.

If system is premix instead of nozzle-mix, regulator outlet pressure is zero, and pressure drop through the regulator would equal inlet gas pressure (12 osi). Table 2 factor is 2.45; 900 ÷ 2.45 = 367 cfh. Select a 7219-1 Regulator from Table 1.

For stainless steel internals in place of standard brass, specify **7219K**. For ambient temperature between 180 F and 300 F, specify **7219V**: Regulator will have Viton-coated dacron diaphragms.

FIELD PIPING FOR 7219 REGULATOR

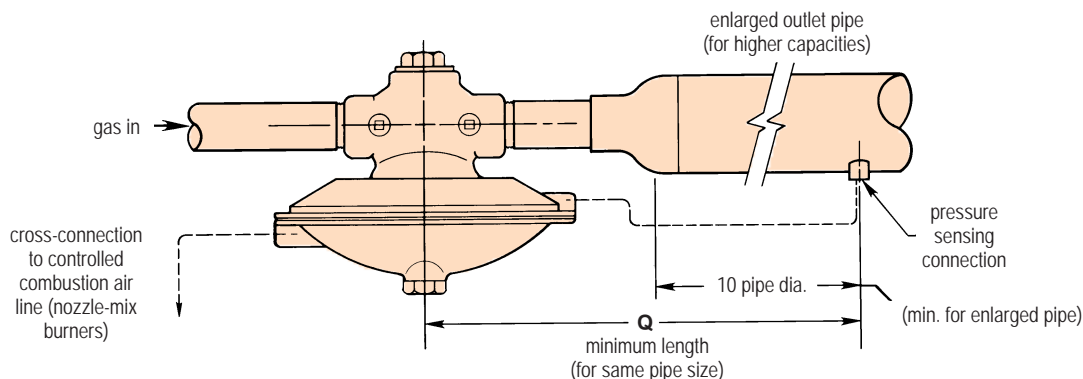

FACTORY PIPED 7219SS REGULATOR

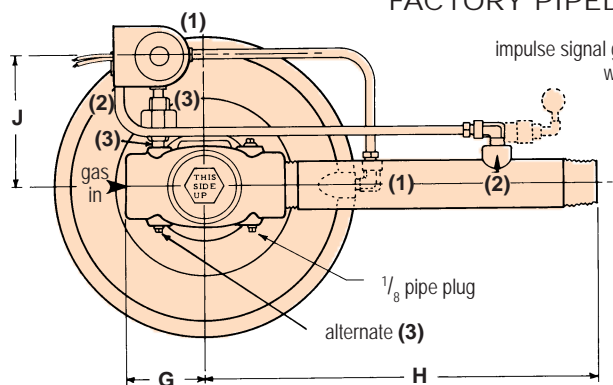

impulse signal goes from (2) through (1) when solenoid is energized

impulse signal goes from (3) through (1) when solenoid is de-energized

numbers in parentheses correspond to solenoid valve port numbers

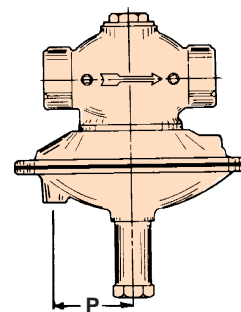

7219-0, -1, -2, -3

DIMENSIONS inches

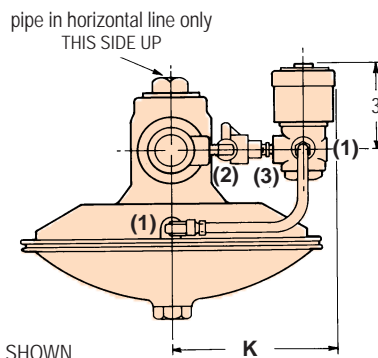
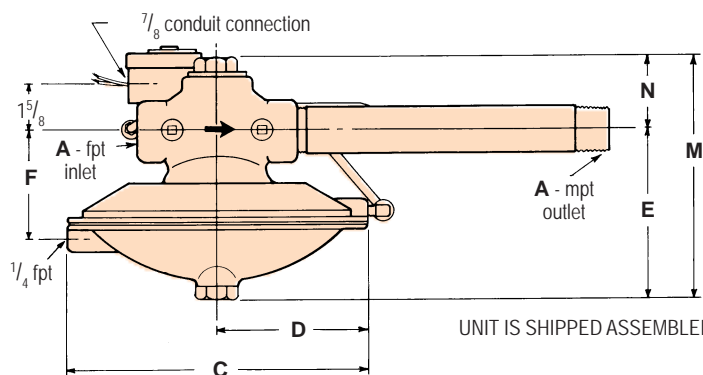

Note: In diagrams above, 7219/7219SS-4 through -7 Regulator configuration is shown: -0 through -3 Regulators have remote connection boss ((1) for 7219SS) on top of diaphragm case (rather than on periphery.)

Regulator designation	dimensions in inches												weight, lb		
	A	C	D	E	F	G	H	J	K	M	N	P	Q	7219	7219SS
7219-0, 7219SS-0	3/4	7 1/2	3 3/4	6 7/8	-	2 1/2	7 5/8	4 5/16	5 1/2	8 3/4	1 7/8	2 11/16	6 5/8	8	12
7219-1, 7219SS-1	1	7 1/2	3 3/4	6 7/8	-	2 3/4	9 7/8	4 3/4	5 13/16	8 15/16	2 1/16	2 11/16	8 7/8	8	12
7219-2, 7219SS-2	1 1/4	10 1/2	5 1/4	5 29/32	-	2 3/4	10 5/8	4 11/16	5 3/4	8 13/32	2 1/2	3 15/16	9 1/4	12	17
7219-3, 7219SS-3	1 1/2	10 1/2	5 1/4	5 29/32	-	3 1/16	12 3/8	4 7/8	5 15/16	8 17/32	2 5/8	3 15/16	11 3/8	13	19
7219-4, 7219SS-4	2	13 1/2	6 3/4	7 3/16	4 9/16	3 5/16	14 1/2	5 1/4	6 5/16	10 7/16	3 1/4	-	13 1/2	17	24
7219-5, 7219SS-5	2 1/2	18 1/2	9 1/4	11 9/16	6 11/32	4 1/2	18	5 13/16	6 7/8	15 15/16	4 3/8	-	17	38	48
7219-6, 7219SS-6	3	18 1/2	9 1/4	11 9/16	6 11/32	4 13/16	21 1/4	6 1/16	7 1/8	16 7/16	4 7/8	-	20 1/4	40	55
7219-7, 7219SS-7	4†	18 1/2	9 1/4	12 1/16	6 27/32	8 21/32	25	7 1/4	8 5/16	17 13/16	5 3/4	-	24	84	103

† Inlet and outlet connections are flanged on -7 (4") size.

DIMENSIONS SHOWN ARE SUBJECT TO CHANGE. PLEASE OBTAIN CERTIFIED PRINTS FROM FIVES NORTH AMERICAN COMBUSTION, INC. IF SPACE LIMITATIONS OR OTHER CONSIDERATIONS MAKE EXACT DIMENSION(S) CRITICAL.

WARNING: Situations dangerous to personnel and property may exist with the operation and maintenance of a combustion equipment. The presence of fuels, oxidants, hot and cold combustion products, hot surfaces, electrical power in control and ignition circuits, etc., are inherent with any combustion application. Parts of this product may exceed 160F in operation and present a contact hazard. Fives North American urges compliance with National Safety Standards and insurance Underwriters recommendations, and care in operation.

Fives North American Combustion, Inc., 4455 East 71st Street, Cleveland, OH 44105 USA, Phone 216.271.6000
Fax 216.641.7852 email: fna.sales@fivesgroup.com • www.fivesgroup.com/fivesna