



7052 Ratiotrols proportion oil flow to combustion air flow in cross-connected control systems. Outlet oil pressure from the Ratiotrol is proportional to the impulse air signal. Therefore, as combustion air is turned up or down, the Ratiotrol causes oil to follow it in proportion. Desired air/oil ratio is set with a manual valve (1813 Sensitrol™ Oil Valve) at the burner.

**MULTIPLE BURNERS**

A single Ratiotrol can serve several burners when it is cross-connected downstream of the zone air control valve **if** burners are on one side of furnace and difference in their elevation is less than 12".

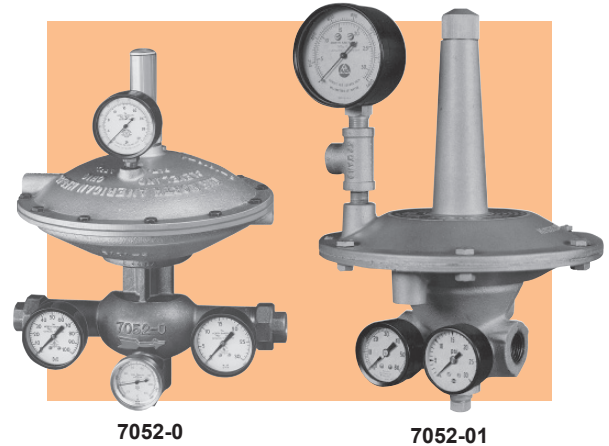

Table 1

**CAPACITIES  
gph (#2 oil)**

Ratiotrol	air impulse pressure, osi			
	8	12	16	24
<b>7052-01</b>	55	67	78	95
<b>7052-01-V</b>	36	45	52	63
<b>7052-0</b>	161	197	227	274
<b>7052-0-V</b>	101	123	142	171

**EXPANSION CHAMBERS**

If Ratiotrol is in light oil line between valves that are closed when burners are shut off, radiant heat from furnace could expand oil trapped in the line, bursting Ratiotrol diaphragms and damaging gauges. Install one or more 8521-01 Expansion Chambers downstream of Ratiotrol to prevent this. See page 2 for selection data.

**SPECIFICATIONS**

**Maximum oil temperature:**

- 180 F for standard 7052
- 300 F for 7052- -V (with Viton diaphragms)

**Oil grades:**

- 7052-01:** light oils only
- 7052-0:** #1 through #6. Heated #6 probably requires special construction and other provisions, e.g. -V Viton diaphragms.

**Optional gauges (and thermometer):**

7052-01-WG: inlet and outlet oil pressure gauges with gauge cocks, air impulse pressure gauge

7052-0-WTG: inlet and outlet oil pressure gauges with gauge cocks, air impulse pressure gauge, dial thermometer

**Recommended Inlet Pressures**

Size	Air impulse (osi)	Inlet pressure (psig)
<b>7052-01</b>	6-32	25
	36	30
	40	35
<b>7052-0</b>	6-16	25
	20	30
	24	35
	34	45

**Multiplication Factor**

Size	Low flow	Maximum flow
<b>7052-01</b>	9:1	7:1
<b>7052-0</b>	14:1	10.5:1

**Spring Bias:** 7052-01: +1.9–1.5 psi  
7052-0: +3.2–2.5 psi

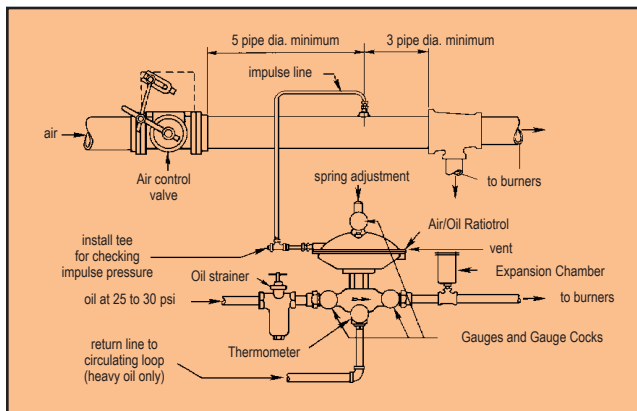

**Figure 1.** Piping of Ratiotrol used for several burners on light or heavy oil, or single burner on heavy oil.

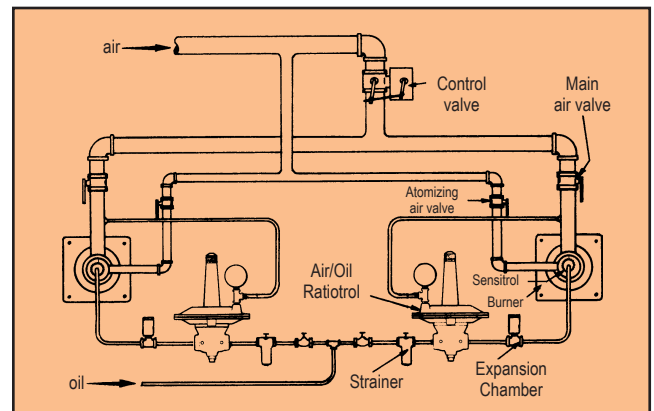

**Figure 2.** Arrangement for burning light oil with a separate Ratiotrol for each burner.

## DIMENSIONS

inches

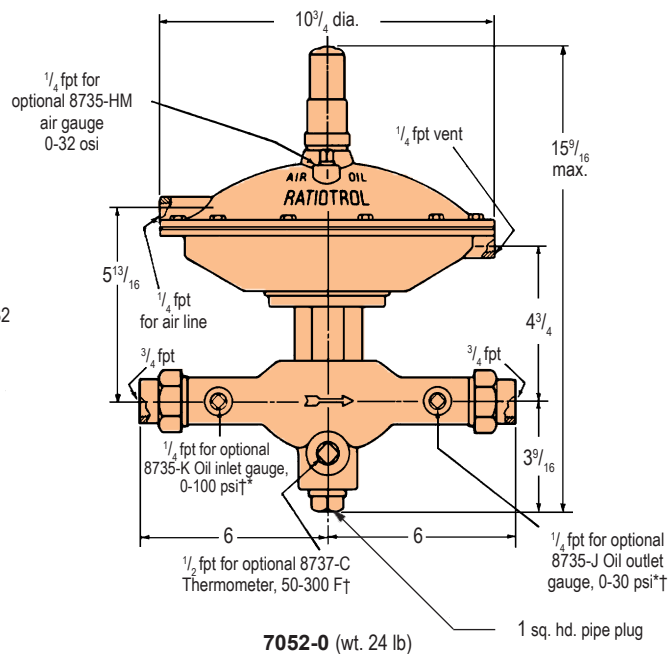
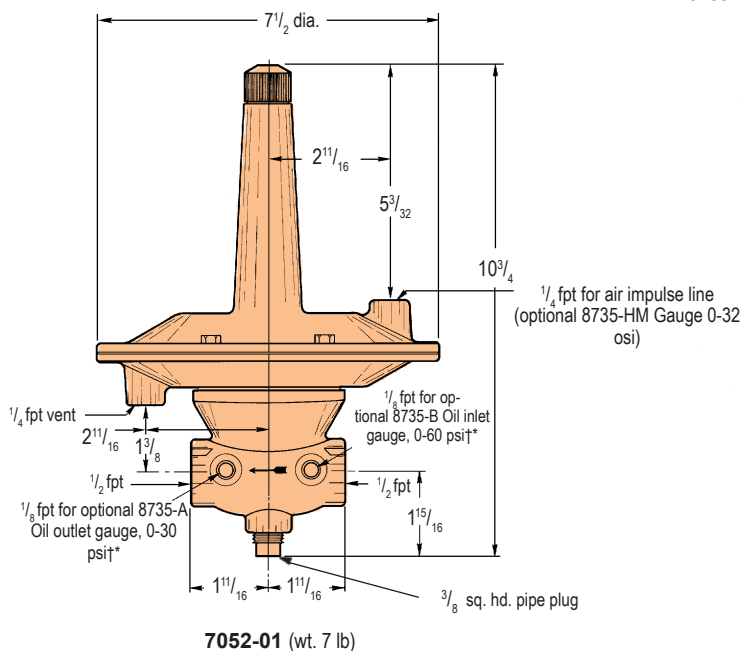

See photograph on front for actual vent and impulse locations.  
Thermometer and gauges not standard equipment.

† On both sides of body.

\* Gauges shall be isolated from pulsation damage during operation of the burner system with the use of 1836-04 gauge cocks on -01 and 1836-03 on -0 size.

Ratiotrols™ must be mounted horizontally, and diaphragm case should be above the pipe.

DIMENSIONS SHOWN ARE SUBJECT TO CHANGE. PLEASE OBTAIN CERTIFIED PRINTS FROM FIVES NORTH AMERICAN COMBUSTION, INC.  
IF SPACE LIMITATIONS OR OTHER CONSIDERATIONS MAKE EXACT DIMENSION(S) CRITICAL.

## 8521-01 Expansion Chamber (for light oil only)

Oil that becomes heated after it is trapped in a line will expand and can build up enough pressure to rupture regulator diaphragms unless provision is made to absorb expansion. It is good practice to install 8521-01 Expansion Chambers downstream of Ratiotrols to protect them in light oil installations.

Heavy oil systems normally use recirculating loops in oil lines, with a relief valve to return oil to main tank.

This table of pipe lengths accommodated by one 8521-01 Expansion Chamber is based on a 10 F oil temperature rise on Schedule 40 pipe.

nominal pipe size	length, feet
1/4"	800
3/8"	435
1/2"	270
3/4"	155
1"	95
1 1/4"	55
1 1/2"	40

If temperature rise exceeds 10°F, the length of pipe accommodated decreases proportionally.

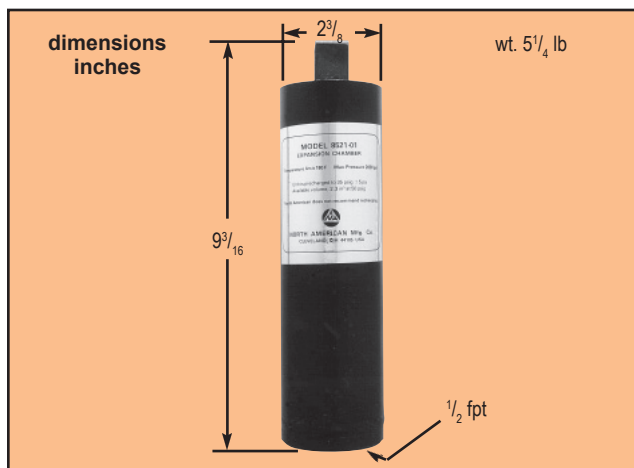

### SPECIFICATIONS

- Design: For systems with oil pressures 30 psi or less cold.  
When heat causes system pressure to reach 50 psi, 8521-01 Chamber has absorbed 4 cu. in. of oil.
- Maximum ambient temperature: 180 F
- Maximum pressure: More than 300 psi.  
Charged with 35 psi dry nitrogen (do not recharge).
- Construction: Buna-N bladder. Steel body.

**WARNING:** Situations dangerous to personnel and property may exist with the operation and maintenance of an combustion equipment. The presence of fuels, oxidants, hot and cold combustion products, hot surfaces, electrical power in control and ignition circuits, etc., are inherent with any combustion application. Parts of this product may exceed 160F in operation and present a contact hazard. Fives North American Combustion, Inc. urges compliance with National Safety Standards and insurance Underwriters recommendations, and care in operation.