

- **4725- -E**
Direct spark ignition

- **4725- -G**
Spark-ignited gas pilot

- **4725- -M**
Manually-ignited gas pilot

BENEFITS

Adjustable flame geometry:

- Engineered combination of diffusion flame and variable partial premix via primary air adjustment permits flame shaping as required to match tube geometry.
- Partial premix provides early heat release to tube surface adjacent to burner.
- Delayed mixing results in highly radiant diffusion flame, distributing heat release more uniformly along length of radiant tube.
- More uniform tube temperature results in longer tube life and better control of product temperature.

Designed for low maintenance and reliable ignition:

- Unique ignition arrangement eliminates the need for high-maintenance, bayonet-style pilot or long electrodes.
- Pilots and electrodes are located in cool zone near furnace wall.
- First wave of partial premix results in reliable ignition and attachment of the flame front to the flame anchor.
- Glow pilots available for easy visual checking.
- Investment cast HT30 flame retainer enhances service life (included on all versions, E, G, H and M).

Evenglow burners include: built-in V-port adjustment, primary air adjustment, observation port, and one of three ignition methods.

Mounting and Installation. Each burner is flanged for easy mounting on a radiant tube. See Table 1a for suggested tube

sizes. In general, the distance from the burner flange to the inside of the furnace wall should not exceed 18". This avoids overheating the tube inside the wall. For greater wall thicknesses consult Fives North American. For additional information on installation, see Sheet 4725-1.

Table 1a. CAPACITIES and TUBE SIZES. Capacities shown are with 30% primary air (+70% secondary air). For capacities in Btu/hr, multiply cfh air capacity by 100. Apply correction factor from Table 1b for 20% or 40% primary air operation.

Burner designation	cfh Air Capacity with Air Pressure across the burner of						Radiant Tube inside diameter
	1 osi	5 osi	6 osi	8 osi	12 osi	16 osi	
4725-2-E, -G, or -M	585	1300	1430	1650	2010	2330	3 ³ / ₄ " min to 4 ¹ / ₈ " max
4725-3-E, -G, or -M	885	1980	2160	2500	3050	3540	3 ³ / ₄ " 5 ³ / ₄ "
4725-4-E, -G, or -M	1450	3240	3540	4100	5000	5800	4 ³ / ₄ "† 6 ¹ / ₈ "
4725-5-E, -G, or -M	2370	5300	5800	6700	8150	9500	5 ³ / ₄ " 6 ¹ / ₈ "
4725-6-E	3710	8300	9100	10500	12900	14800	5 ³ / ₄ " 8 ¹ / ₄ "

Table 1b. Primary Air Screw Adjustments Required for 20%, 30% and 40% Primary Air

Adjusting Screw Turns Open		4725-2	4725-3	4725-4	4725-5	4725-6
20% Primary Air, 87.5% rated capacity	Full Closed	0	0	0	0	0
30% Primary Air, 100% rated capacity	—	4	6 ¹ / ₂	3	3	7
40% Primary Air, 117% rated capacity	Full Open	13+	13+	12+	6 ¹ / ₂	10+

Air Capacity

Capacities in Table 1a are for burners with 30% primary air. Burners are shipped with the primary air adjusting screw closed, corresponding to 20% primary air and 87.5% of Table 1a capacities.

Primary air may require adjustment for smooth operation on some tube configurations.

Wide open adjustment of primary air screw increases primary air to about 40% and total air capacity to about 117% of Table 1a figures. Table 1b shows approximate number of turns of air adjusting screw for 30% and full open primary air. Installations using greater than 30% primary air should have blower capacity increased accordingly.

Preheated Air

For air preheats to 900 F use 4725- -EH described on Sheet 4725-5.

Propane

Evenglow burners are suitable for use with propane gas, but the primary air must be adjusted wide open to avoid soot formation.

Lighting Arrangements

4725- -E Direct Spark Ignited Burners. The main flame is lighted by a simple electrode igniter located behind the flame front for cool long-life operation. The spark should be turned on before the burner gas valve is opened; after the burner

is lighted, the spark must be turned off for proper burner operation. During the ignition period, a continuous 6000 volt spark is required. Spark distributor systems cannot be used with 4725- -E Burners.

4725- -G and 4725- -M Gas Piloted Burners include gas pilots that glow, permitting the furnace operator to see at a glance if pilots are burning. A mixture pressure of 3"wc produces a bright red glow, visible after 2 minutes' warm-up. The pilot has 15,900 Btu/hr capacity at the maximum allowable mixture pressure of 3"wc and requires a 4031 Mixer.

4725- -G Burners include a glow pilot and spark plug. A 6000 volt transformer is required. After lighting, the spark should be turned off to prolong electrode life. Spark distributor systems can be used with this burner.

4725- -M Burners have manually ignited glow pilots, with a special lighter hole closing device to stop air infiltration.

CONTROL AND ADJUSTMENT

Burner must be lighted at low fire (1 osi max). Air pressure on 4725- -G and 4725- -M must not go below values in Table 2 even with on-off control. Refer to Sheets 4725-1 and 4725-4 for additional instructions and requirements.

Accurate air/gas ratios can be determined by using 8697 Metering Orifices in the fuel and air lines, or by Orsat flue gas analysis.

Table 2. MINIMUM BURNER AIR PRESSURE

with gas pilots. Add tube backpressure.

4725- -G or -M Burner Size	Glowing Pilot at 3"wc mixture pressure	Pilot Operated Non-glow at 1 ¹ / ₂ "wc mixture pressure
-2	0.6 osi	0.3 osi
-3	0.3 osi	0.2 osi
-4	0.3 osi	0.2 osi
-5	0.2 osi	‡

Table 3. MINIMUM GAS PRESSURE FACTORS

for natural gas. Consult North American for factors for other gases.

4725- -E, -G, or -M Burner Size	Factor	To find the approximate minimum natural gas pressure required across the burner for the capacity ratings of Table 1, multiply the high fire air pressure across the burner by the factor shown.
-2	0.06	See example under "Selection."
-3	0.12	
-4	0.06	Do not use this table to set air/gas ratios.
-5	0.12	
-6-E	0.26	

† When mounting on a tube with I.D. less than 5³/₄", a 1/8" thick gasket is required between the burner mounting flange and the radiant tube flange.

‡ Cannot be operated non-glow because 3"wc mixture pressure is required.

Blower Sizing

Because the primary air adjustment may be opened to 40%, the blower should have 117% (from Table 1b) of the rated total burner capacity.

Flame Supervision

Refer to Bulletin 8832, page 3, for choices of flame detectors and adapters.

Selection

Example. Select gas piloted radiant tube burners for an installation requiring 350,000 Btu/hr gross heat release in each tube, with 8 osi air pressure across the burners. Glow pilots are desired. The tube backpressure is estimated to be 0.1 osi.

Solution. To allow for possible adjustment of primary air to 20% for best heat-distribution in the tubes, divide the required capacity by 87.5% (from Table 1b).

Capacity to use for burner selection = $350,000 \div 0.875 = 400,000$ Btu/hr.

From Table 1a, select 4725-4-G Burners which are rated at 410,000 Btu/hr with 8 osi air.

Capacity to use for blower selection = $4100 \text{ cfm} \times 1.17 \times$ number of burners.

From Table 2, the minimum combustion air supply pressure for glow pilots should be $0.3 + 0.1$ backpressure = 0.4 osi.

From Table 3, the minimum gas supply pressure should be 0.06×8 osi air pressure = 0.48 osi.

Order Must Specify

1 — Burner Designation: 4725

2 — Size: -2, -3, -4, -5, -6

3 — Ignition System: E, G, or M

For example, a typical complete designation would be "4725-3-G".

4725 DIMENSIONS

inches

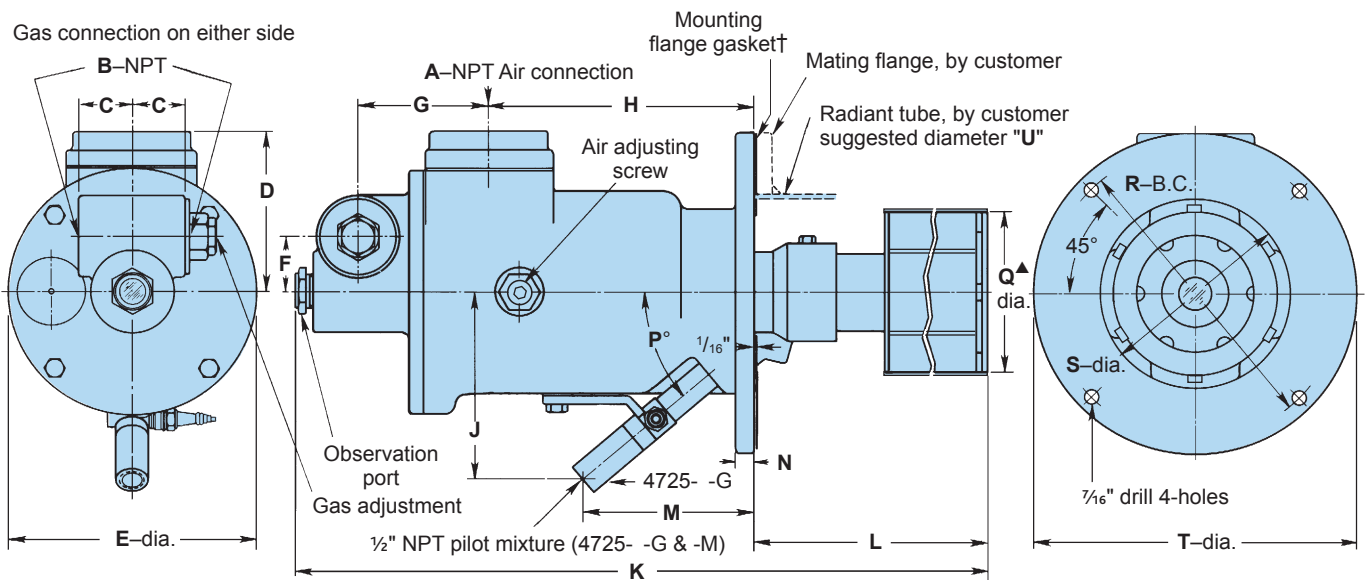

† Mounting flange gasket is not part of the burner and must be ordered separately. See Page 4 for part number.

Burner designation	dimensions in inches and degrees																	Wt, lb		
	A	B	C	D	E	F	G	H	J	K	L	M	N	P°	Q [▲]	R	S		T	U
4725-2-E, -G or -M	1¼	1	1½	4	5⅞	1⅝	3⅜	6¾	4⅝	20	8¾	6¼	½	30	3	7	3 ²³ / ₃₂	8	4	30
4725-3-E, -G or -M	1½	1	1½	4	5⅞	1⅝	3⅜	6¾	4⅝	20	8¾	6¼	½	30	3	7	3 ²³ / ₃₂	8	4	30
4725-4-E, -G or -M	2	1¼	1⅞	4⅝	7½	1⅞	4¼	7	5¾	22⅞	9⅞	5⅝	⅞	40	4	9	5 ²³ / ₃₂	10	6	50
4725-5-E, -G or -M	2½	1½	1⅞	4⅝	7½	1⅞	4¼	8⅞	5¾	25	11	5⅝	⅞	40	5	9	5 ²³ / ₃₂	10	6	60
4725-6-E	3	1½	1⅞	5⅝	7½	1⅞	4¼	8⅞	5¾	25	11	5⅝	⅞	40	5	9	5 ²³ / ₃₂	10	8	60

▲ "Q" diameter across ribs, add ¼".

DIMENSIONS SHOWN ARE SUBJECT TO CHANGE. PLEASE OBTAIN CERTIFIED PRINTS FROM FIVES NORTH AMERICAN COMBUSTION, INC. IF SPACE LIMITATIONS OR OTHER CONSIDERATIONS MAKE EXACT DIMENSION(S) CRITICAL.

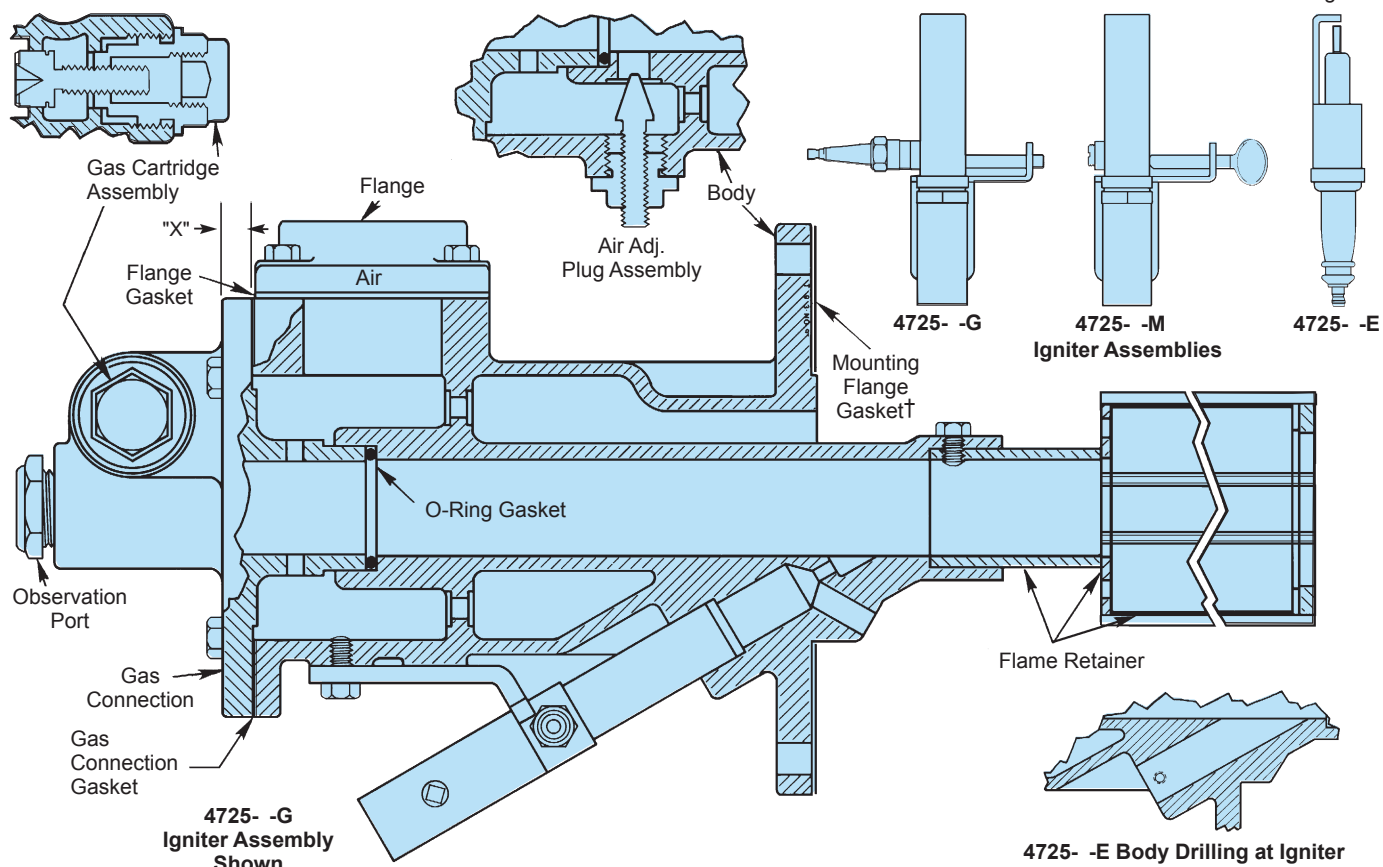

Part name	Burner designation				
	4725-2	4725-3	4725-4	4725-5	4725-6-E
Air Adj. Plug	4-3709-1	4-3709-1	4-3293-1	4-3752-1	4-3752-1
Air Adj. Plug (Hot Air)	4-3709-2	4-3709-2	4-3293-2	4-3752-2	4-3752-2
Air Adj. Plug Assembly	4-7715-1	4-7715-1	4-7715-3	4-7715-4	4-7715-4
Body 4725- -E	4-3509-13	4-3509-14	4-3564-7	4-3449-9	4-3449-11
Body 4725- -G	4-3509-11	4-3509-12	4-3564-6	4-3449-8	—
Body 4725- -M	4-3509-11	4-3509-12	4-3564-6	4-3449-8	—
Flame Retainer (standard "L")	4-28521-1	4-28521-1	4-28522-1	4-28523-1	4-28523-1
Flame Retainer (extended "L")†	4-28524-__	4-28524-__	4-28525-__	4-28526-__	4-28526-__
Flange	2-4170-1	8765-3-B	8765-4-C	8765-5-C	8765-6-C
Flange Gasket	4-5371-1	4-5371-1	4-5371-2	4-5371-2	4-5371-2
Gas Cartridge Assembly	4-6062-3	4-6062-3	4-6062-4	4-6062-5	4-6062-5
Gas Connection Gasket*	4-22039-1	4-22039-1	4-22039-2	4-22039-2	4-22039-2
Gas Connection Gasket (Hot Air)	4-22039-3	4-22039-3	4-22039-4	4-22039-4	4-22039-4
Gas Connection	4-3510-7	4-3510-8	4-3565-2	4-3448-3	4-3448-4
Igniter Assembly 4725- -E	4-3681-1	4-3681-1	4-3681-1	4-3681-1	4-3681-1
Igniter Assembly 4725- -G	4-5072-4	4-5072-4	4-5072-4	4-5072-4	—
Igniter Assembly 4725- -M	4-5072-3	4-5072-3	4-5072-3	4-5072-3	—
Mounting Flange Gasket†	4-6540-2	4-6540-2	4-6540-1	4-6540-1	4-6540-1
O-Ring Gasket	R289-8730	R289-8730	R289-8752	R289-8731	R289-8731
Observation Port	8790-0	8790-0	8790-0	8790-0	8790-0

* Should minor air leakage occur between the body and gas connection castings on burners manufactured prior to September, 1996, it will be necessary to install this new gasket. At the same time, it will be necessary to replace the copper-clad "gasket" and install a new gas connection. All three parts are to be ordered from the factory. Part numbers are listed in the above chart. To verify that you have received the proper gas connection, the "X" dimension of 25/64" should be checked.

† Mounting flange gasket is not part of the burner and must be ordered separately.

‡ For extended "L" dimension flame retainers ("L" dimension in 1/2" increments from L = 12" to L = 24") insert required "L" dimension in the blank space. For example: 4-28524-14 for 4725-2/3 flame retainer with "L" dimension of 14" or 4-28526-16.5 for 4725-5/6 flame retainer with "L" dimension of 16 1/2". For complete burner assemblies with extended "L" dimensions, consult factory for special part numbers.

Parts Order Must Specify: 1 – Burner Designation 2 – Part Name 3 – Part Number

WARNING: Situations dangerous to personnel and property may exist with the operation and maintenance of any combustion equipment. The presence of fuels, oxidants, hot and cold combustion products, hot surfaces, electrical power in control and ignition circuits, etc., are inherent with any combustion application. Parts of this product may exceed 160F in operation and present a contact hazard. Fives North American Combustion, Inc. urges compliance with National Safety Standards and insurance Underwriters recommendations, and care in operation.