



These rugged nozzle-mix burners have been used for many years on high temperature furnaces such as those for forging steel, melting aluminum or brass, and reheating steel bars or ingots...and on low temperature ovens and air heaters.

Their sealed-in construction allows maximum efficiency through close control of air/gas ratio, furnace atmosphere, and furnace pressure--all contributing to better product quality.

4514 FIRE•ALL Burners, as the name suggests, are appropriate for a wide variety of industrial heating applications. Nominal capacities range from 1 500 000 to 21 000 000 Btu/hr (see Table 1 below).

TILES/INSTALLATION

Burner tiles are cast refractory rated for 2800 F furnace temperature. They are replaceable in the field, except for the 4514-10 whose mounting must be returned to the factory for tile replacement (or purchase a spare mounting plate with a tile cast onto it).

Burner tiles should be supported securely in the furnace wall by a layer of castable refractory (not insulation) at least 9" thick all around the tile, extending back to the furnace shell and securely anchored to it. (See Supplement DF-M1.)

For furnace walls thicker than the length of the tile, the tunnel beyond the end of the tile should be flared 30-45° from the centerline, starting at the OD of the tile. If this is physically impractical, consult North American for specific recommendations.

Jacketed Tiles. 4514 Burners are available with support jackets around the tile for applications where the tile is not supported by furnace refractory.

Jackets are available in three different metals and have maximum temperature ratings for each. They must be protected with sufficient insulation so as not to exceed rated temperature.

Maximum temperature rating for jacket metals depends upon frequency of heat-up/cool-down cycles. As an example, batch annealing furnaces that are heated and cooled every day should use the "intermittent exposure" ratings. Continuous annealing furnaces that remain at the same temperature for months at a time, can use the higher "continuous" rating.

Designation	Jacket Metal	Continuous max.temp.	Intermittent exposure
4514- -LC	carbon steel	700 F	700 F
4514- -L4	304 stainless	1600 F	1500 F
4514- -L9	309 stainless	1900 F	1800 F

Table 1. COMBUSTION AIR CAPACITIES

scfh
(for Btu/hr, multiply by 100)

Burner designation	air pressure drop across the burner in osi							approximate flame length stoichiometric ratio	available excess air ratio setting
	0.1	1	5	6	8	12	16		
4514-6	1 180	3 710	8 300	9 100	10 500	12 900	14 900	4 1/2'	300%
4514-7	1 930	6 100	13 600	15 000	17 200	21 000	24 400	5'	650%
4514-8-A	3 350	10 600	23 700	26 000	30 000	36 700	42 400	8'	450%
4514-8-B	5 550	17 600	39 200	43 000	49 600	60 500	70 000	9'	250%
4514-9	11 600	36 600	82 000	89 500	104 000	127 000	146 000	16'	700%
4514-10	17 300	54 500	122 000	135 000	154 000	189 000	218 000	19'	350%

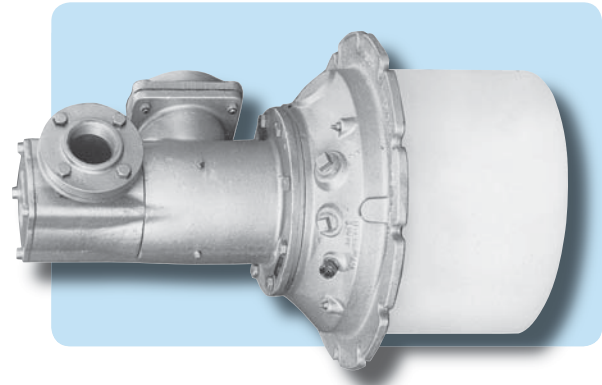

FLAME SUPERVISION

Flame safeguards are recommended for all installations. An ultraviolet cell will monitor pilot or main flame. Pilots must be **interrupted** after a preset ignition period (usually 15 seconds) so flame detectors monitor main flame only. Adapters for mounting flame detection devices on 4514 Burners are tabulated on Bulletin 8832.

OPERATION

Control: Normally, air primary with a cross-connected, pressure-balance regulator. For maximum turndown, use a 7216 (biased) Regulator, or throttle gas only.

To protect burner from heat damage, do not set air pressure below 1 osi in a 1900 F furnace, or below 2 osi at 2200 F (whether gas is on or off).

Gas pressure requirement: About 1 osi at the burner for natural gas on stoichiometric ratio; about 1/5 of the air pressure for coke oven gas.

Lighting: See reverse side for recommended premix pilot tips.

Preheated air: 4514 Burners are suitable for some applications with air preheated to 700 F: consult North American re limitations.

DUAL FUEL

6514 FIRE•ALL Burners are available for oil standby or combination gas and oil firing. See Bulletin 6514. 4514 Gas Burners can be converted to 6514 Dual-Fuel™ Burners with an appropriate conversion kit (see Parts List 4514-2).

DIMENSIONS — Main air and gas connections can be rotated relative to one another and to the mounting plate. Drawings show connections as assembled at the factory. Arrangements shown reduce maintenance by minimizing dirt accumulation in pilots and flame supervisory devices. Pilot and main air connections cannot be aligned in the same direction.

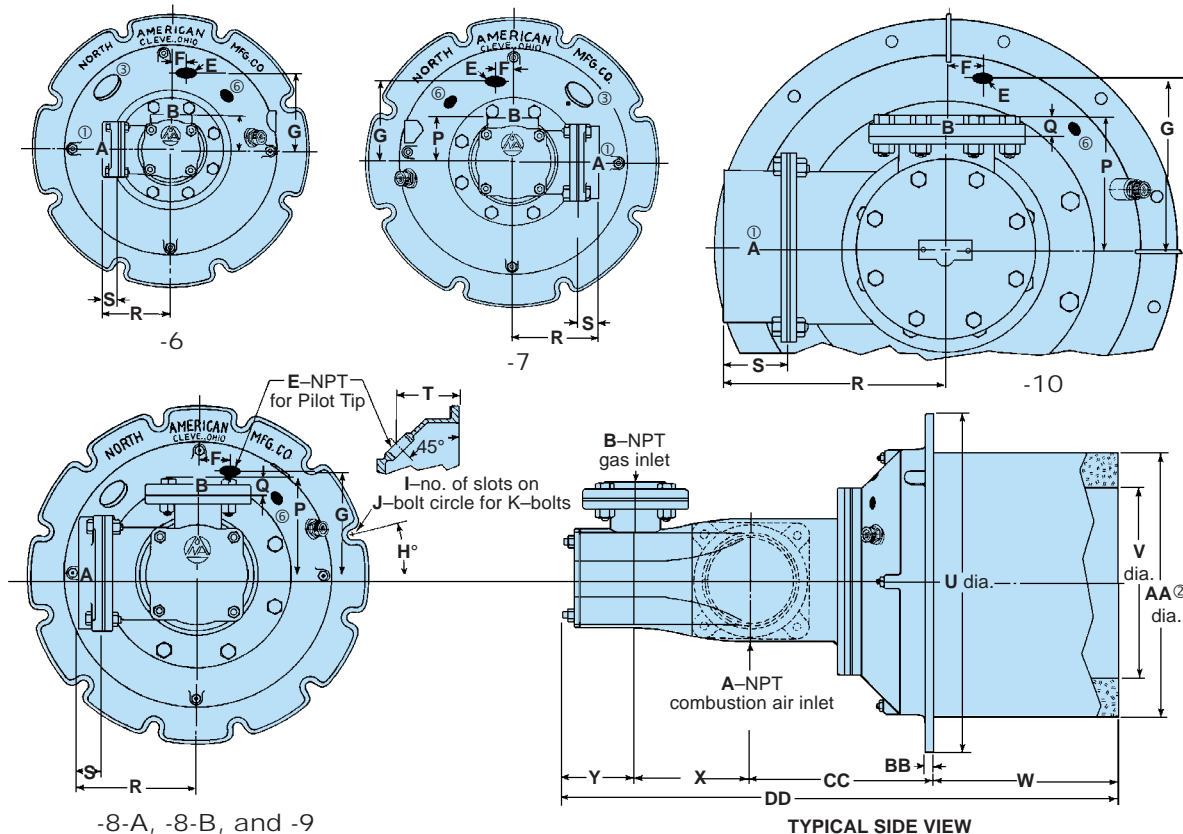

DIMENSIONS SHOWN ARE SUBJECT TO CHANGE. PLEASE OBTAIN CERTIFIED PRINTS FROM FIVES NORTH AMERICAN COMBUSTION, INC. IF SPACE LIMITATIONS OR OTHER CONSIDERATIONS MAKE EXACT DIMENSION(S) CRITICAL.

Burner designation	common dimensions in inches for 4514 and 4514- L															
	A ^⑦	B	E	F	G	H°	I	J	K	P	Q	R	R ₁ ^④	S	T	U
4514-6	3	2	3/4	1	5 ¹⁷ / ₃₂	22 ¹ / ₂	8	18	5/8	2 ¹ / ₂	—	5 ³ / ₁₆	10 ³ / ₈	1 ¹ / ₂	3 ⁵ / ₁₆	19 ¹ / ₂
4514-7	4	2 ¹ / ₂	1 ¹ / ₄	1 ¹ / ₄	5 ³ / ₄	22 ¹ / ₂	8	19	5/8	3 ¹ / ₄	—	6 ¹ / ₁₆	10 ¹ / ₈	1 ¹ / ₂	3 ⁵ / ₁₆	20 ¹ / ₂
4514-8-A	6	2 ¹ / ₂	1 ¹ / ₄	1 ¹ / ₂	6 ⁷ / ₈	15	12	21 ¹ / ₄	5/8	3 ⁷ / ₈	—	7 ⁵ / ₁₆	11 ¹ / ₄	1 ³ / ₄	4 ⁵ / ₁₆	22 ³ / ₄
4514-8-B	6	3 ^⑤	1 ¹ / ₄	2 ¹ / ₄	7 ³ / ₈	15	12	22 ¹ / ₂	5/8	6 ³ / ₄	1 ³ / ₁₆	8 ⁷ / ₁₆	12 ³ / ₈	1 ³ / ₄	4 ⁵ / ₁₆	24
4514-9	8	4 ^⑤	1 ¹ / ₂	2 ¹ / ₄	9 ⁷ / ₈	15	12	26 ¹ / ₂	5/8	8 ³ / ₄	1 ⁵ / ₁₆	13 ³ / ₈	—	3 ¹³ / ₁₆	6 ³ / ₁₆	28
4514-10	10	6 ^⑤	1 ¹ / ₂	2 ¹ / ₂	12 ³ / ₁₆	15	12	30 ¹ / ₂	3/4	9 ⁵ / ₈	1 ⁹ / ₁₆	15 ⁷ / ₁₆	—	4 ³ / ₈	5 ¹⁵ / ₁₆	32 ¹ / ₂

Burner designation	for both series				for 4514 only				wt lb	for 4514 -- L only				wt lb	Pilot Tip
	V	W	X	Y	AA ^②	BB	CC	DD		AA ^⑤	BB	CC	DD		
4514-6	10 ³ / ₈	9	3 ¹⁵ / ₁₆	2 ¹¹ / ₁₆	15	5/8	8 ⁵ / ₁₆	23 ⁵ / ₁₆	160	16	3/4	8 ⁷ / ₁₆	24 ¹ / ₁₆	185	4021-12
4514-7	11 ³ / ₈	9	4 ¹¹ / ₁₆	2 ¹³ / ₁₆	16	5/8	9 ¹ / ₄	25 ³ / ₄	210	17	3/4	9 ³ / ₈	25 ⁷ / ₈	240	4025-0-T
4514-8-A	12 ³ / ₈	10	6 ⁵ / ₁₆	3 ³ / ₈	17 ³ / ₄	5/8	12 ⁷ / ₈	32 ⁹ / ₁₆	300	18 ³ / ₄	3/4	13	32 ¹¹ / ₁₆	335	4025-0-T
4514-8-B	13 ¹ / ₂	13	8 ³ / ₁₆	4 ⁷ / ₈	19	5/8	12 ⁷ / ₈	38 ¹⁵ / ₁₆	405	20	3/4	13	39 ¹ / ₁₆	450	4025-0-T
4514-9	16	13 ¹ / ₂	11 ⁵ / ₁₆	5 ³ / ₄	23	5/8	14 ¹¹ / ₁₆	45 ¹ / ₄	700	24 ¹ / ₄	1 ³ / ₁₆	14 ⁷ / ₈	45 ⁷ / ₁₆	750	4025-2-T
4514-10	20 ¹ / ₂	13 ⁷ / ₁₆	13 ¹ / ₁₆ ^⑦	6 ³ / ₈	27 ¹ / ₂	1/2	16 ¹ / ₈	49	980	27 ¹ / ₂	1 ¹ / ₁₆	16 ⁵ / ₁₆	49 ³ / ₁₆	1010	4025-2-T

- ① Flanged connection -- NA square threaded flange for sizes -6, -7, -8, but SW style inlet may be specified. SW inlet (suitable for slip-on or welded connection) is standard for -9 and -10 burners.
- ② Opening in furnace shell or outer wall must be 1/2" larger than dimension "AA" to allow for mounting plate fillet and draft.
- ③ Blank boss (for optional uses with oil and dual-fuel models).
- ④ Applies when optional SW inlet is specified.
- ⑤ Flanged connection -- ANSI 125 psi threaded flange.
- ⑥ 1" fpt for electrode or UV flame detector.
- ⑦ 4514-10 only is offered with a short (2") tile designated 4514-10-S.

ANSI or SW flanges: Flat face companion flanges and full gaskets are supplied with this equipment. Do not use raised face flanges that may damage mating flange.

WARNING: Situations dangerous to personnel and property may exist with the operation and maintenance of any combustion equipment. The presence of fuels, oxidants, hot and cold combustion products, hot surfaces, electrical power in control and ignition circuits, etc., are inherent with any combustion application. Parts of this product may exceed 160F in operation and present a contact hazard. Fives North American urges compliance with National Safety Standards and insurance Underwriters recommendations, and care in operation.

Fives North American Combustion, Inc., 4455 East 71st Street, Cleveland, OH 44105 USA, Phone 216.271.6000
Fax 216.641.7852 email: fna.sales@fivesgroup.com • www.fivesgroup.com/fivesna