

SCOPE – These instructions are intended as a general guide for installing round or square burner tiles in hard refractory lined furnaces. Specific instructions for irregular shaped tiles outside the scope of this discussion should be obtained from the burner manufacturer.

TILE LENGTH – Normally, ideal length for a burner tile is such that its hot face surface is flush with the inside surface of the furnace after installation. However, standard length tiles can usually be installed in furnace walls thicker or thinner than tile length if installed within the following guidelines. (Refer to Figure 1.)

1. (Figure 1A) For furnace walls thicker than tile length: Wall opening, with inside dimensions to accommodate tile outside dimensions, may usually be extended up to one additional tile length, after which port should be flared with at least a 60° included angle extending to the inside furnace wall.
2. (Figure 1B) For furnace walls thinner than tile length: Generally, a burner tile may extend beyond the inside furnace wall up to 1". Extensions greater than 1" should be supported on a mantel or by a metal jacket (if within temperature limitations). Consider also increasing the furnace wall thickness in port area on the outside of the furnace to make tile hot face flush with inside wall.

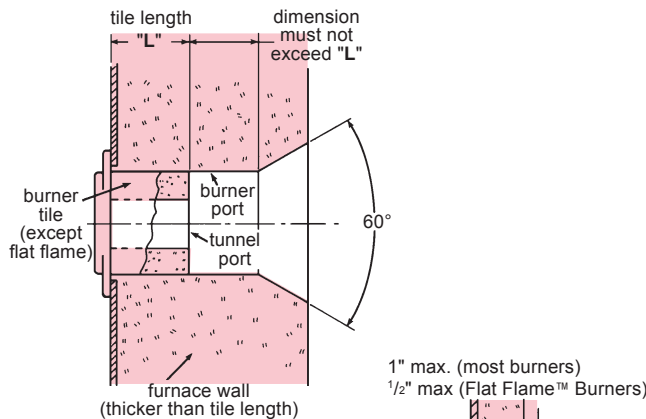

Figure 1A

Figure 1. Tile length relationship to furnace wall thickness.

Figure 1B

3. Hot face of Flat Flame Burner tiles must be flush or no more than 1/2" extended beyond inside wall. Burners must be recessed into or extended out from outside wall to accommodate this requirement.

Recommended method for installing burner tile in a hard refractory lined furnace

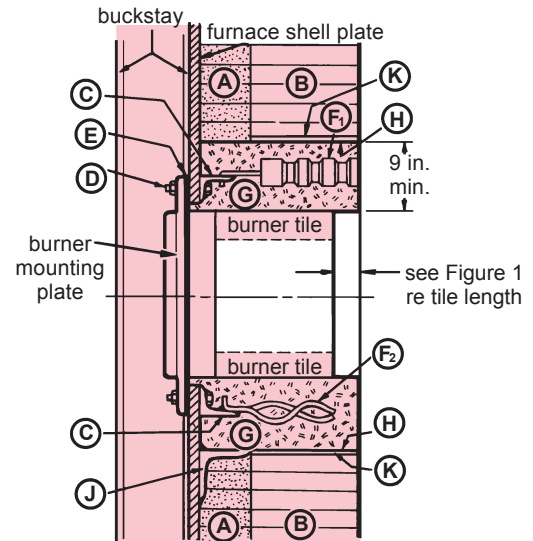

Figure 2. Cross section through a vertical furnace wall showing a recommended method for installing a burner tile. Letters refer to legend below.

Legend for Figure 2

- (A) Insulating refractory or block insulation.
- (B) High temperature refractory. All refractory must be tied securely to furnace shell plate. Horizontal and vertical expansion joints must be provided in surrounding refractory to prevent pressure from being exerted on burner tile.
- (C) Horizontal angles welded to furnace shell plate, extending from buckstay to buckstay. Vertical angles should also be welded to furnace shell plate on either side of the burner.
- (D) Burner mounting bolts with heads welded in place.
- (E) Gasket--may be used to provide better seal between burner mounting plate and furnace shell plate.
- (F) Anchor tiles tied back to angle (preferred to F₂), or
- (F₁) Stainless steel bent-rod anchors, mastic-coated.
- (G²) Castable refractory matrix all around--minimum thickness = 9" or 1/2 the tile OD, whichever is greater. Rammed refractory is an alternative, but anchors then *must* be refractory type. (Castable is preferred because its entire mass sets up without firing.)
- (H) Waterproofing (all around) to prevent surrounding refractory from absorbing water from castable refractory. Plastic sheet is suggested.
- (J) Shelf support angle. This and expansion joint K prevent vertical pressure from being exerted on burner tile. This construction is especially helpful when burners are located high in a wall.
- (K) Expansion joint, densely packed with refractory wool.

PROCEDURE

1. Cut an opening in furnace shell allowing 1/2" (3/4" for larger burners) clearance all around tile or lip on mounting plate.
2. Weld studs or bolts to the shell to match holes in burner mounting plate.
3. Weld angle irons all around burner opening on *inside* of shell.
4. Attach anchor tiles to angle irons.
5. Bolt burner to the wall.
6. Lay up refractory wall allowing for thermal expansion as recommended by refractory supplier--refractory wall must exert no stress on burner or surrounding matrix when furnace is hot or when cold, but there should be no openings in refractory through which furnace gases could reach the shell.
7. Leave an opening all around the burner tile for a rammed or cast refractory matrix as shown in Figure 2. Purpose of this matrix is to make sure burner mounting and tile, matrix, and furnace shell will all move as a unit in the event of unequal expansion of refractory wall and shell. This construction is designed to eliminate failures shown in Figures 3 and 4.
8. Ram or cast a matrix† of high temperature low shrinkage refractory in space between burner tile and refractory wall to obtain tight contact with tile, brickwork, shell, angle iron, and anchors. Ramming or pouring should be completed quickly to minimize layering.
9. After all refractory has hardened, connect piping to burner using flexible connections (e.g., N.A. Bulletin 8770).

† Matrix can be installed by either of the following methods:

- a) Lay up refractory brick to level of top of matrix opening. Pour castable around tile or ram plastic refractory from above (using form on inside of furnace wall). When castable or plastic hardens, lay up brick above it.
- b) Lay up brick several courses above matrix opening using a spanner tile, lintel, or arch to span the matrix opening and ram from inside furnace. Enough brick must be laid above span to permit ramming against it.

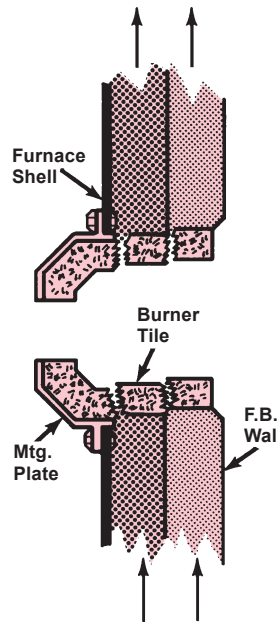

Figure 3. Tile shears off due to unequal expansion of refractory and shell or unequal expansion between layers of refractory brickwork and matrix around tile prevent this.

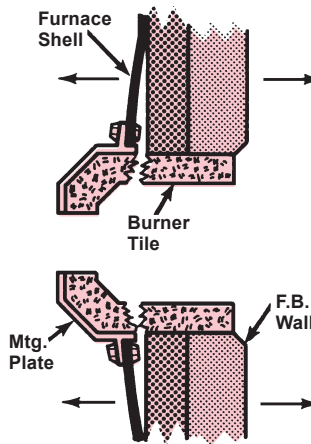

Figure 4. Tile fails in tension as a result of bowing or buckling of the shell or brickwork. Prevent this by using more rigid shell, buckstay, and bracing construction. Install high temperature matrix as shown in Figure 2 to avoid passages that would permit "fluing" of gases through brickwork to the shell.

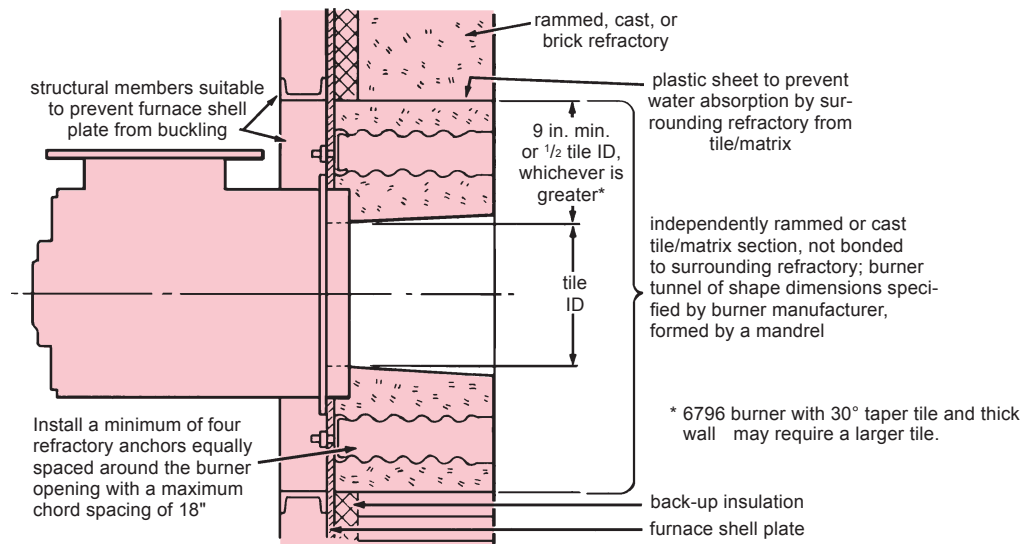

Figure 5. For large burners with which no refractory tile is supplied. Expansion joints must be provided in surrounding refractory to prevent pressure being exerted on cast or rammed burner tunnel section.

WARNING: Situations dangerous to personnel and property may exist with the operation and maintenance of any combustion equipment. The presence of fuels, oxidants, hot and cold combustion products, hot surfaces, electrical power in control and ignition circuits, etc., are inherent with any combustion application. Parts of this product may exceed 160F in operation and present a contact hazard. Fives North American urges compliance with National Safety Standards and insurance Underwriters recommendations, and care in operation.