

**6855-4 Car Thawing Unit complete with weather shield. Shown with optional (recommended) Sensitrol™ Oil Valve.**

Hot Dog Burner Car Thawing Assemblies provide a fast and economical means of heating hopper cars for easier dumping of frozen loads of coal, ore, and other bulk materials. The car hoppers and sides are heated both by convection, from a stream of hot air mixed with the products of combustion which flow through the perforations in the Hot Dog covers, and by radiation from the flame and the red hot alloy covers.

This combination of convection and radiation heating promotes rapid thawing without subjecting the journal boxes to excessive temperatures. Furthermore, fuel costs are reduced when compared to thawing pits or electric heating, which depend on radiation alone.

6855-4 Hot Dog Burners combine the 6422 Nozzle-Mix Burner with the time-proven 6856 firing trough. This combination results in a reliable, low maintenance unit that can be supplied with automatic lighting, electronic flame supervision, and the ability to control the burner input from a remote location.

### OPERATING CHARACTERISTICS

The burner fires the length of the firing trough, on which two covers rest end to end. A baffle plate at the far end of the trough forces the hot flue gases to escape through perforated holes in these covers. When the weather resistant refractory lining of the trough becomes hot, it directs radiant energy toward the car.

The 6855 Burner will operate equally well on either excess air or stoichiometric air/fuel ratio. It is ruggedly constructed to withstand the elements and contains provisions for flame supervision and either a gas pilot or direct spark ignition. For this reason, car thawing sheds can be equipped with remote pushbutton start up, thereby eliminating the need for the operator to light each burner manually.

### NO THAWING PITS REQUIRED

Hot Dog Burners do not require pits, thereby avoiding not only drainage problems, but the possible hazard of someone accidentally stepping into one.

### SPECIFICATIONS

**Nominal Input:** Approximately 600,000 Btu/hr, when operating on stoichiometric ratio. The burner may also be operated with up to 10% excess fuel which, along with induced secondary air, increases the input to 660,000 Btu/hr.

**Main Air Capacity:** 5400 scfh at 16 osi.

**Atomizing Air Capacity:** 430 scfh at 4 osi for burning gas.



**Typical Hot Dog installation.**

800 scfh at 14 osi for burning oil.

**Fuels:** Natural gas, propane, coke oven gas and distillate fuel oils. Required gas pressure at the burner is less than 2 osi. Required oil pressure at the burner is less than 4 osi.

**Ignition:** A 4055-M Direct Spark Igniter is recommended for gas only. Dual-Fuel™ or oil burners may be lit either with a 4021 Pilot Tip or manually with a torch.

**Flame Supervision:** A flame rod or UV cell may be used when firing gas only. A UV cell may be used when firing dual fuel or oil only.

A weather shield is provided with the burner, which protects the igniter and flame detector from the elements.

Hot Dog Burner covers are constructed of a corrosion resistant, high temperature alloy. Retainers have been installed to hold the covers in place even if the burner is mounted at a 45 degree angle. In addition, the trough is sloped to provide for natural drainage of rain water or melted snow.

### INSTALLATION & SELECTION

Hot Dog™ Burners are normally installed four-across; two between the rails and one on either side, 5½' from the tracks centerline. The outer burners should be mounted on 6856-R risers, (2 required per burner).

The number of burners required for an installation depends on the number and length of cars to be thawed at one time. When planning the burner layout, allow a 5½' length for each burner and a 4' space between burner rows (four burners across).

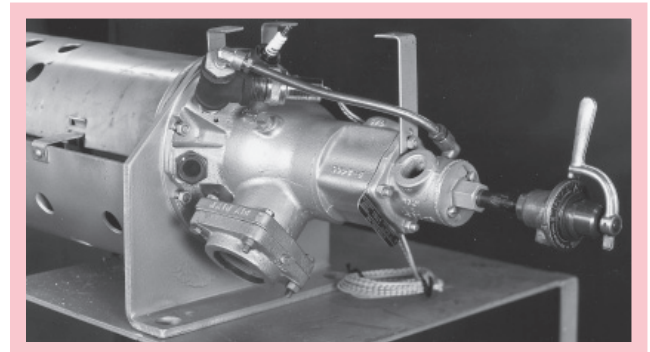

**Burner with weather shield removed. Shown with optional (recommended) Sensitrol™ Oil Valve.**

**IMPORTANT:**

Hot Dog Burners produce large amounts of heat which is transferred by convection and radiation. Care must be taken when positioning the burners under and along the sides of the cars to ensure that they will not overheat exposed equipment such as hoses, journal boxes, axles or brake cylinders.

The trough support legs provide 1" clearance under the burner. This promotes cooling air circulation under the center burners and prevents charring of the ties. THIS SPACING MUST BE MAINTAINED. If there is a clearance problem between the burner and the car hopper, either cut a groove in the ties or elevate the rails in the thawing area to provide the required clearance.

To allow for expansion and contraction of the burner due to temperature changes, the spikes or bolts through the mounting holes at one end of the trough should be a loose fit.

The length of heating time and the burner firing rates necessary to thaw cars without overheating, are determined by operating experience. By monitoring the thawing process, programs may be developed which cover various circumstances, including weather conditions and how solidly the loads are frozen.

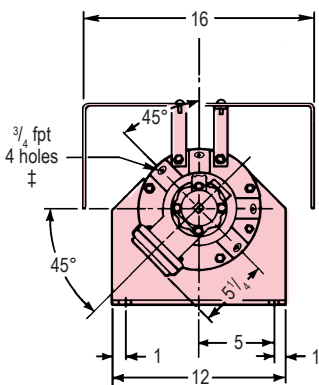
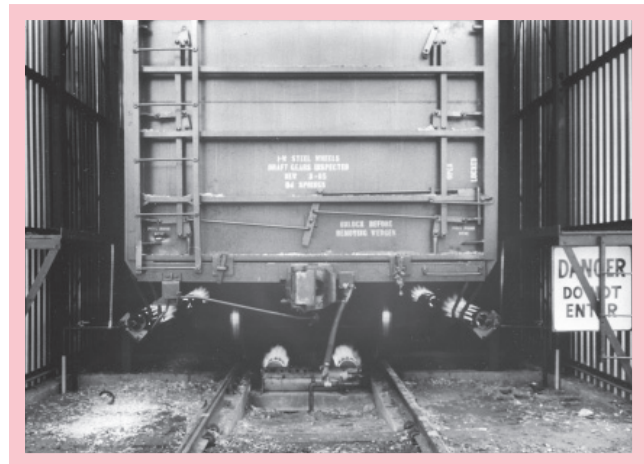
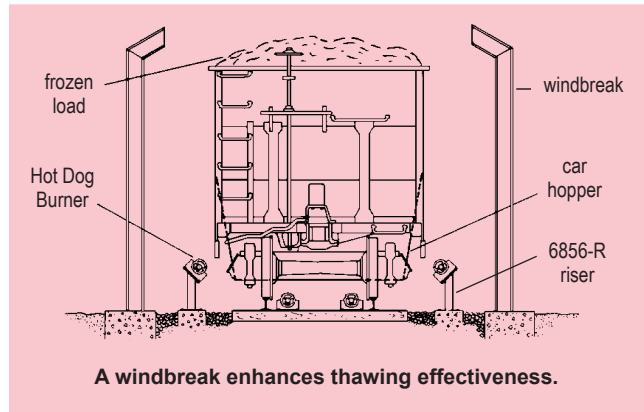

**DIMENSIONS**  
inches

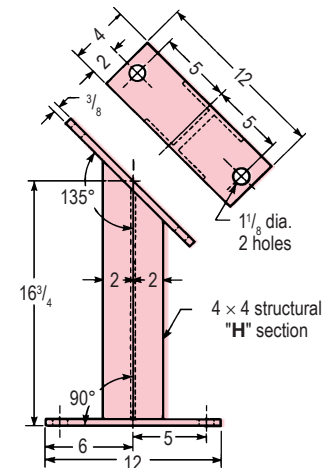
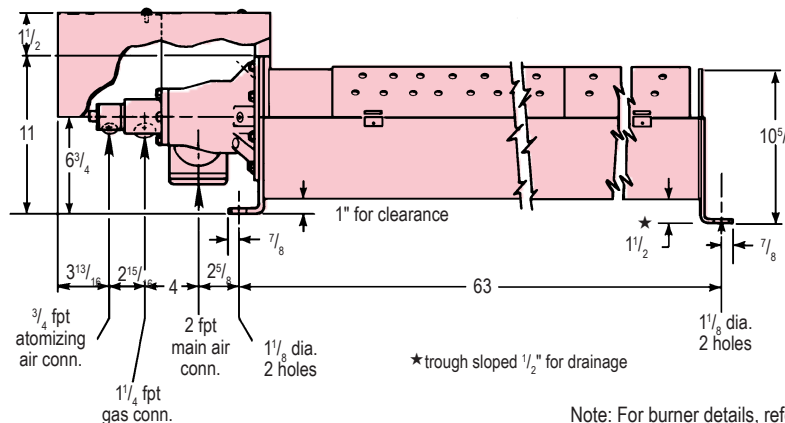

<b>6855-4-CTU</b>	Car Thawing Unit	210 lb
<b>6856-R</b>	Riser	27 lb

Note: For burner details, refer to Bulletin 6422 and Dimensions 6422, using OC3-2042 body with extra pilot and flame detector locations (±).

DIMENSIONS SHOWN ARE SUBJECT TO CHANGE. PLEASE OBTAIN CERTIFIED PRINTS FROM FIVES NORTH AMERICAN COMBUSTION, INC. IF SPACE LIMITATIONS OR OTHER CONSIDERATIONS MAKE EXACT DIMENSION(S) CRITICAL.

**WARNING:** Situations dangerous to personnel and property may exist with the operation and maintenance of any combustion equipment. The presence of fuels, oxidants, hot and cold combustion products, hot surfaces, electrical power in control and ignition circuits, etc., are inherent with any combustion application. Parts of this product may exceed 160F in operation and present a contact hazard. Fives North American urges compliance with National Safety Standards and insurance Underwriters recommendations, and care in operation.

Fives North American Combustion, Inc., 4455 East 71st Street, Cleveland, OH 44105 USA, Phone 216.271.6000  
Fax 216.641.7852 email: fna.sales@fivesgroup.com • www.fivesgroup.com/fivesna