

8883/84 Flame Supervisory System

- Multiple burner applications
- PLC power
- Choice of graphic and/or touch-screen user interfaces
- Integrated combustion safeguard and process control
- Independent burner shutdown
- Modular system design
- Compliant with NFPA and insurance underwriter recommendations
- Communication port for plant floor networks
- Fully tested prior to shipment
- Quick delivery
- Competitively priced

The 8883 is a custom flame supervisory and process control system for multiple burner applications. It is part of the new line of 888X series of Fives North American Combustion Control Systems. The 8883 incorporates such features as color graphics display screens, touch screens, extensive use of personal computers (PC's), programmable logic controllers (PLC's), and the new Honeywell/North American RM7888 industrial burner controllers. These features bring a new look and an impressive increase in control capability.

The 8883 system consists of a single master control enclosure and individual burner boxes. The 8884 is functionally the same as the 8883, but the burner modules are housed in a single enclosure with the master control.

The PC or PLC provides overall process control, monitoring, and alarm reporting. The flexibility such a system allows it to be configured to meet many diverse process needs such as the implementation of special control strategies like StepFire™. In addition, it can accommodate other process control loops, discrete logic control, plus analog and digital inputs and outputs beyond the combustion control operation.

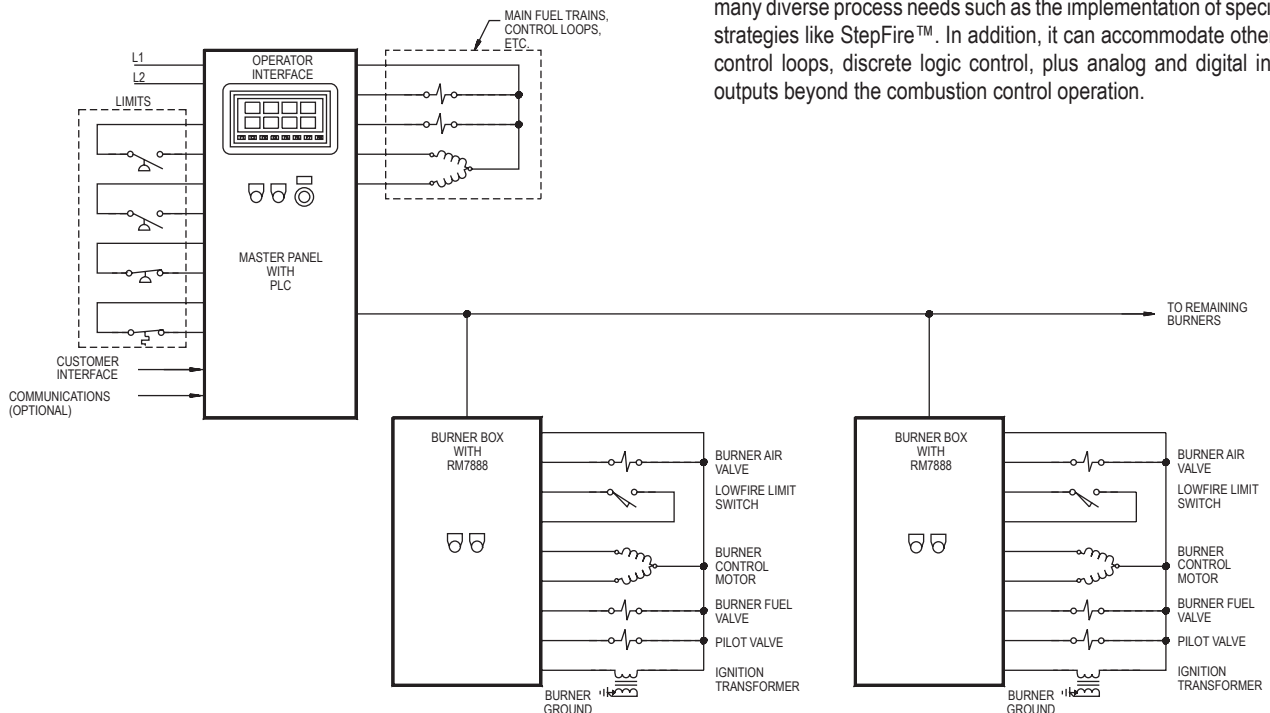

The basic building block of the 8883/84 system, the new Honeywell/North American RM7888 controller, carries out burner management. This flame safeguard unit has extensive capability beyond those of other manufacturers and other earlier Honeywell models. With built-in timing and programming functions, it can handle any flame supervision application from the simplest single burner job to the complex requirements of StepFire™ and TwinBed II™.

Two levels of video display operator interface are available to accommodate customer preference and need. Complete graphics user interface (GUI) in a Windows™ environment with detailed and dynamic color screens, mouse, and full manual/auto control access comes in the software package with a personal computer to provide the processing power.

Also available, but not as elaborate, is a limited graphics user interface. This package provides lower resolution with graphics that are made up of boxes and lines on a monochrome screen. Full manual/auto control access is provided through function and numeric keys or via touch-screen. As with the full graphics user interface, the pictures can be organized in a hierarchy with an overview screen "at the top" and sub-screens providing more detailed information about specific parts of the process.

Either video capability or both can be used to monitor and control a process. As process needs increase, the demands on the operators and desires of management dictate that the more elaborate operator interface become part of the system supplied.

Careful design drawn from a long history of experience in combustion processes assures that the system will meet NFPA and insurance underwriter recommendations. A UL label can be provided on request.

8883/8884 Features/Benefits

2 to 36 burners*

- Pilot or direct spark
- Single or dual-fuel
- Any valve train configuration
- Manual or automatic valves with or without closure switches

Zone or individual burner control

- Modulated (P.A.T. or C.A.T.) or StepFire™
- Loop control within the PLC or from dedicated controller

Operator interface with full color graphics

- Pentium class personal computer and VGA CRT with Windows™
- Sophisticated process diagrams
- Real time and historical data storage and retrieval
- Trend plots
- Control loop faceplates
- Alarm information

and/or

LCD video display

- Simplified screens with limited graphics
- Function keys, and/or touch-screen entry

* Systems for more burners can be accommodated. Consult Cleveland.

WARNING: Situations dangerous to personnel and property may exist with the operation and maintenance of any combustion equipment. The presence of fuels, oxidants, hot and cold combustion products, hot surfaces, electrical power in control and ignition circuits, etc., are inherent with any combustion application. Parts of this product may exceed 160F in operation and present a contact hazard. Fives North American urges compliance with National Safety Standards and insurance Underwriters recommendations, and care in operation.

Fives North American Combustion, Inc., 4455 East 71st Street, Cleveland, OH 44105 USA, Phone 216.271.6000
Fax 216.641.7852 email: fna.sales@fivesgroup.com • www.fivesgroup.com/fivesna