

March 1995

Standard Fives North American blowers can be used with inlet air temperatures up to 250 F. Beyond this point, it is necessary to substitute steel for aluminum, and to protect motor and motor bearings (or pillow block bearings) from excessive heat.

2600 Blowers handle hot air or flue gas up to 600 F maximum. They are particularly useful as exhaust fans in TwinBed II™ Heat Reclamation systems. Used as exhaust fans, blowers develop less suction than would be equivalent to their pressure ratings. These blowers hold nearly constant pressure while delivering any volume within their rated capacity range. Their most common function is to supply combustion air to industrial furnaces and kilns. They also are useful for conveying, drying, pressurizing, and other pneumatic applications.

The 2600 series is premium quality in performance, construction, low noise level, and longevity. Unless subjected to physical or environmental abuse, a 2600 Blower will last indefinitely even when operated continuously--its motor may require service occasionally (dependent on ambient conditions).

SELECTION:

Pressures and capacities are shown on succeeding pages of this Bulletin. While motors with 1.15 (115%) service factor are more and more available (even in TEFC construction), it is wise to allow some capacity safety margin when picking a blower for a calculated cfm requirement--unanticipated piping leaks, variations in burner capacity, and other unforeseen factors could cause motor overload unless there is some cushion. Without prior knowledge of leakage and other conditions, a 10% safety margin is considered minimum. Also, it is important to allow for pressure losses in piping, fittings, and valves, which reduce pressure available at the burners (or other end use).

Altitude and preheated air affect blower ratings--pressure, capacity, and horsepower. For blower selection/performance at altitudes significantly above sea level, refer to the blower section of the North American COMBUSTION HANDBOOK. Generally, standard motors can be used up to 3300 feet elevation; special construction is recommended above 3300 feet.

CONSTRUCTION:

Heavy gauge fabricated steel housings, steel bases, and steel impellers are standard. Stainless steel is available. Impellers are precision balanced by Fives North American for smooth, quiet operation. Every blower is factory tested for pressure and volume, and a written record of its test performance is permanently kept by Fives North American. Specific information about a blower manufactured 20 years ago--which occasionally is sought when an impeller requires replacement, or other maintenance is needed--can be furnished via serial number of the blower and its record in Cleveland files.

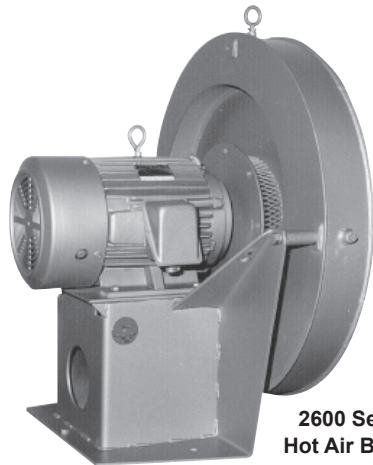

**2600 Series
Hot Air Blower**

**2600 Series
Hot Air Blower**

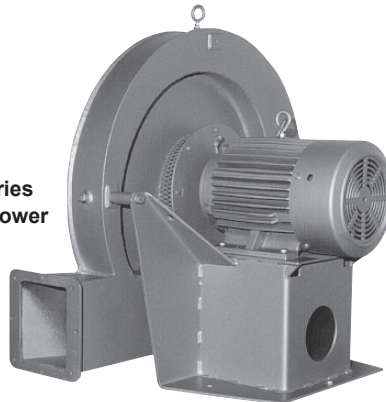

Select correct discharge position when ordering to avoid changes in the field.

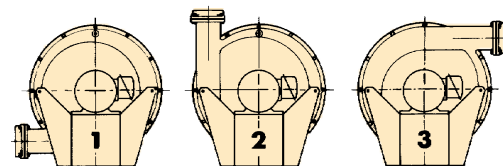

Standard discharge positions (viewed from motor side).

FEATURES:

- Steel housing and impeller(s).
- Heat slinger and heat shield.*
- Single width inlet and outlet.
- Drain plug in housing.
- Motor specs:
 - TEFC with 1.15 service factor.
 - Class B design with Class F insulation.
 - Extended shaft with keyway.
 - 60Hz.

* A carbon steel heat shield is installed on the inner housing, and a heat slinger is used on the shaft between blower and motor or fan end pillow block.

2600 Blowers are designated as follows:

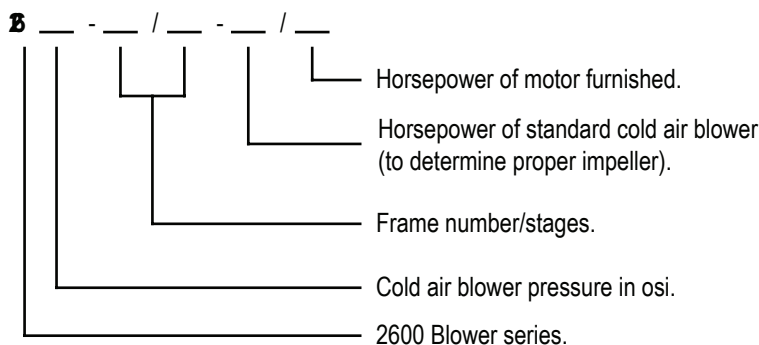

The horsepower of the motor furnished is the maximum available. This horsepower may decrease with the actual number of pounds being utilized.

2600 BLOWER RATINGS
with 70 F air

Blower designation	1.0 S.F.		Blower designation	1.0 S.F.	
	acfh	osi		acfh	osi
2616-F-15/15	145,000	16.1	2620-33/1-25/25	174,000	21.1
2616-F-20/20	192,000	16.0	2620-33/1-30/30	204,000	21.2
2616-F-25/25	221,000	16.4	2620-33/1-40/40	270,000	20.9
			2620-33/1-50/50	348,000	19.8
2616-19/1-3/3	20,400	16.7	2620-33/1-60/60	420,000	18.2
2616-26/1-5/5	37,200	17.1			
2616-35/1-10/10	78,000	17.3	2624-19/2-3/3	12,600	24.0
2616-35/1-15/15	120,000	16.6	2624-26/2-5/5	22,200	25.3
2616-33/1-25/25	198,000	17.1	2624-26/2-7.5/7.5‡	36,000	24.6
2616-33/1-30/30	246,000	16.2			
			2624-33/1-25/25	144,000	24.6
2620-19/2-3/3	17,400	20.2	2624-33/1-30/30	168,000	25.0
2620-26/2-5/5	30,000	20.6	2624-33/1-40/40	222,000	24.9
2620-26/2-7.5/7.5‡	43,200	21.6	2624-33/1-50/50	312,000	25.3
2620-35/1-10/10	60,000	21.0	2624-33/1-60/60	372,000	23.7
2620-35/1-15/15	102,000	20.4			
			2632-21/2-25/25	90,000	33.6
2620-F-15/15	105,000	20.0	2632-33/2-50/50	192,000	34.6
2620-F-20/20	162,000	20.1	2644-21/2-50/50	150,000	43.5
2620-F-25/25	180,000	21.2			

‡ When both horsepower are 7.5, enter order as 2620-26/2-7/7.5 or 2624-26/2-7/7.5 Blower.

Other blowers can be furnished for 600 F air, using modifications similar to those listed above. On applications where blower is protected against cold air overload or seldom handles cold air, e.g., TwinBed II fired continuous furnace exhaust fans, the "hot" horsepower requirement is less than the cold air standard and a smaller motor can be specified.

Determining the most appropriate motor is discussed at length in North American's COMBUSTION HANDBOOK; or a Fives North American engineer can work with you to consider the entire combustion system as well as the blower. For coupled, V-belt drive, or blowers not listed, consult Blower Business Group, Cleveland.

SUCTION AND HOT AIR PRESSURES DEVELOPED BY TURBO BLOWERS

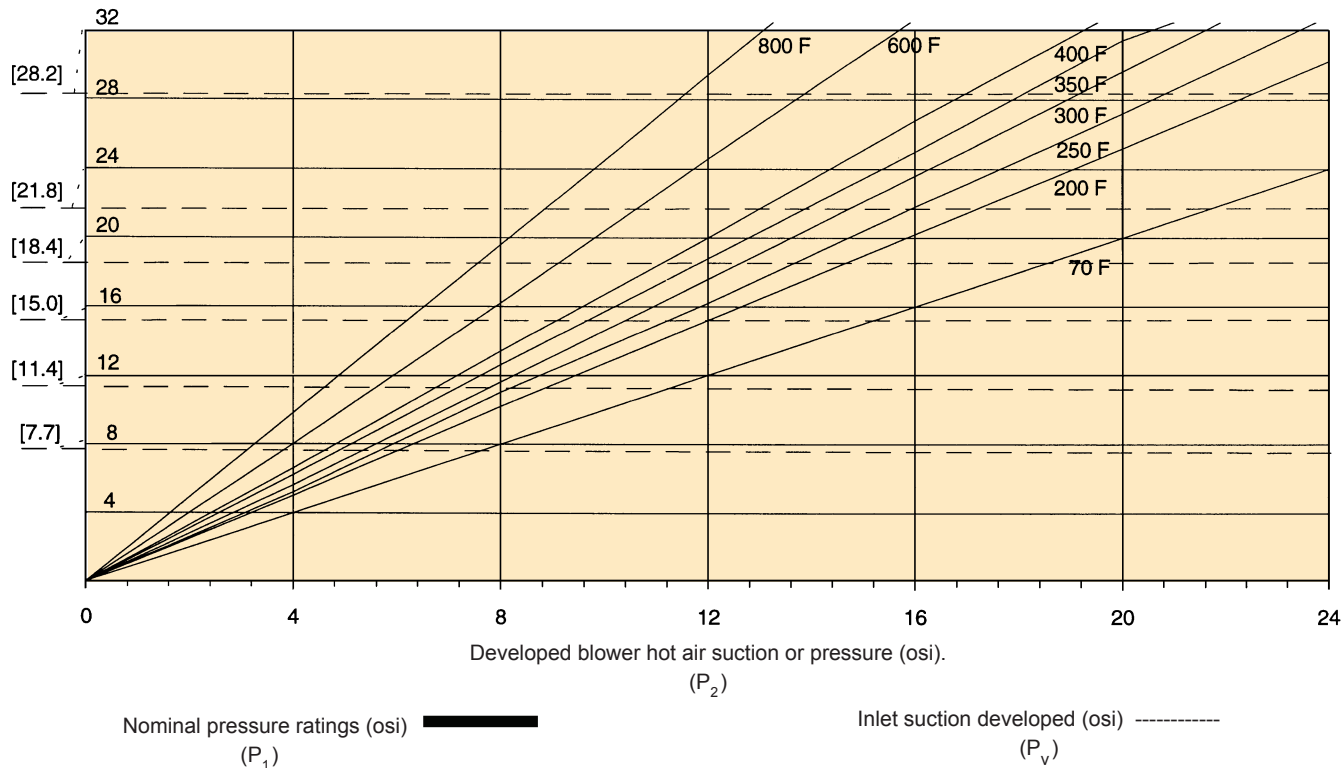

BLOWER LAWS:

The specific weight r per cubic foot of a gas decreases as the air temperature increases, as shown in the following formula:

$$P_{hot} = P_{cold} \left(\frac{T_1 (^\circ F) + 460}{T_2 (^\circ F) + 460} \right)$$

For a given blower with fixed speed and fixed inlet and discharge resistances, the effect of a change of the specific weight, r , of the fluid being handled is:

$$Q_2 = Q_1 \quad \frac{p_2}{p_1} = \frac{r_2}{r_1} \quad \frac{hp_2}{hp_1} = \frac{r_2}{r_1}$$

Note that although the actual volume handled by the blower is unchanged, the equivalent volume flow rate of standard (stp) air, Q' , would be:

$$\frac{Q'_2}{Q'_1} = \frac{r_2}{r_1}$$

Example: To find suction developed by a 16 osi blower with 600 F air, find 16 on the vertical axis and follow slanted dotted line down to 15 osi suction developed with cold air. Follow that dotted line right to intersection with 600 F curve and read 7.4 osi suction on the horizontal axis below.

To find the pressure developed in the same situation, follow the solid 16 osi line to intersection with the 600 F curve and read 7.8 osi on the horizontal axis.

WARNING: Situations dangerous to personnel and property may exist with the operation and maintenance of any combustion equipment. The presence of fuels, oxidants, hot and cold combustion products, hot surfaces, electrical power in control and ignition circuits, etc., are inherent with any combustion application. Parts of this product may exceed 160F in operation and present a contact hazard. Fives North American urges compliance with National Safety Standards and insurance Underwriters recommendations, and care in operation.