

UNIQUE FEATURES OF NORTH AMERICAN SERIES 8485 CONVECTION TYPE RECUPERATORS

Counterflow of products of combustion (poc) and combustion air gives highest heat transfer effectiveness. (There is no need for parallel flow to protect components because of the lower [1650 F] temperature limit.)

The seals (teflon bushings) are at the cold air end— for long life.

– if the seal should ever leak, cold air will be lost—not valuable hot air.

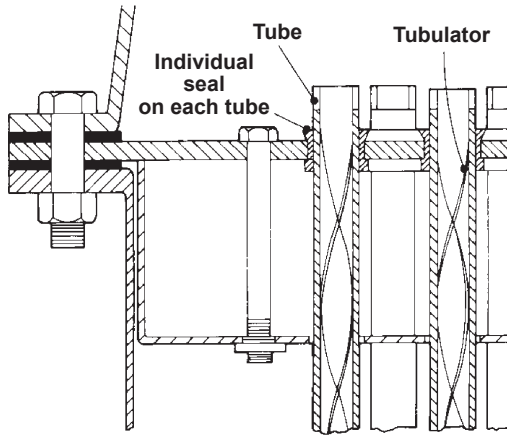

If criss-crossing hot poc happens to heat some tubes hotter than others, they can expand more—without stress in the "tube sheet" or other tubes.

Heat transfer surfaces (tubes) expand in this direction through seals at the cold air end. Rigid joint (rolled, expanded, flared) is at the hot air end.

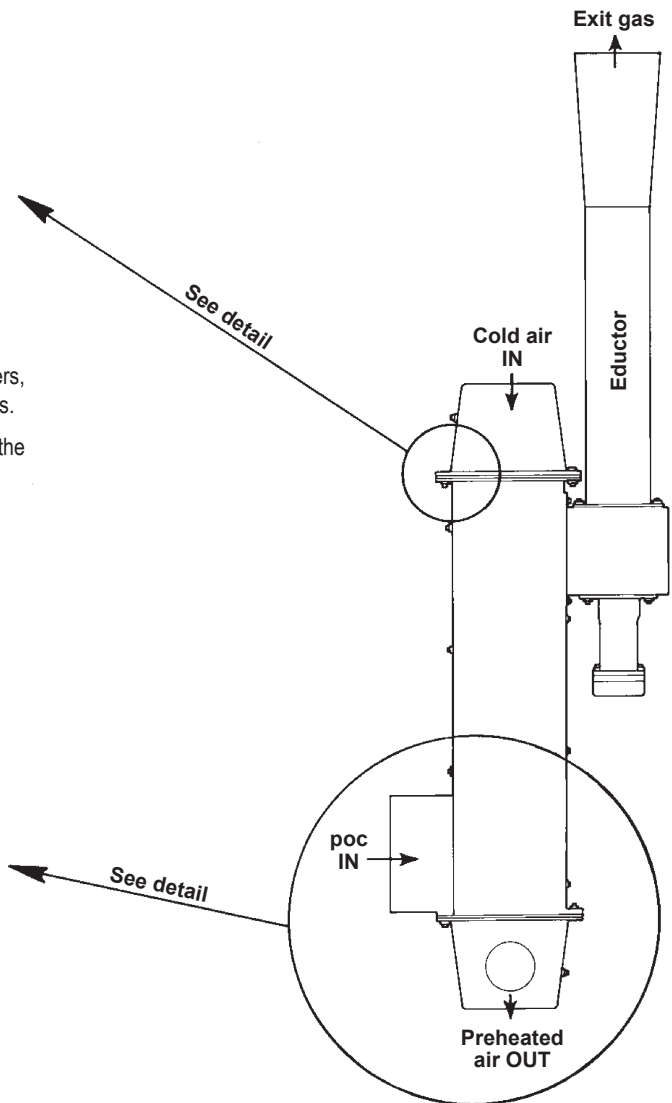
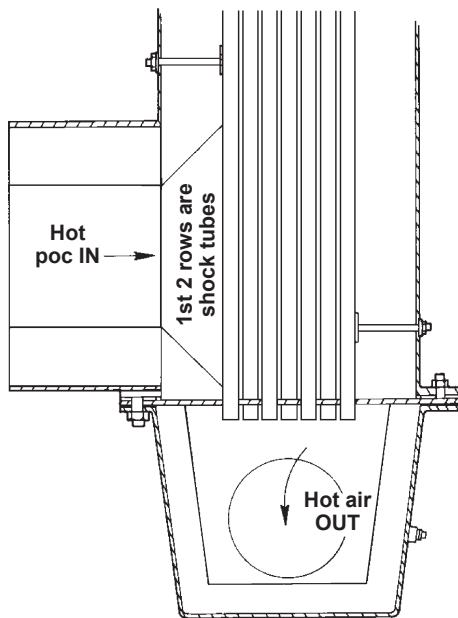

NOTE: If poc is >1600 F, turbulators are omitted from 1st two rows of tubes to increase air flow through those tubes that "look" into the incoming poc duct. This prevents overheating of the shock tubes.

WARNING: Situations dangerous to personnel and property may exist with the operation and maintenance of any combustion equipment. The presence of fuels, oxidants, hot and cold combustion products, hot surfaces, electrical power in control and ignition circuits, etc., are inherent with any combustion application. Parts of this product may exceed 160F in operation and present a contact hazard. Fives North American urges compliance with National Safety Standards and insurance Underwriters recommendations, and care in operation.

Fives North American Combustion, Inc., 4455 East 71st Street, Cleveland, OH 44105 USA, Phone 216.271.6000
 Fax 216.641.7852 email: fna.sales@fivesgroup.com • www.fivesgroup.com/fivesna