

- CAPACITIES:** 3000 to 100 000 scfh air
- FLUE GAS TEMPERATURE:** 1800 F maximum
- PERFORMANCE:** 1000 F air preheat with 1400 F waste gases
- TYPE:** metal tube, cross/counterflow
- INSULATION:** inside steel shell--no additional insulation required

Description—

8485 Recuperators recover heat from clean flue gases up to 1800 F maximum. Heat treat and many other furnaces are suited for the 8485 to improve furnace efficiency.

High heat transfer rates are achieved with cross/counterflow design. Combustion air flows through small diameter alloy tubes and is heated by waste gases traveling in the opposite direction outside the tubes. Tubes are fixed at the hot end but can individually expand or contract thanks to packing gland seals at the cool air end.

An integral eductor pulls waste gases through the recuperator. It requires 16 osi air at about the same volume as combustion air (approximately 90% at 16 osi). If a hot air exhaust fan is available, the eductor can be omitted. Furnace pressure can be maintained in a single zone furnace by control of eductor air.

8485 Recuperators are offered in seven capacities and two tube lengths (preheat capabilities), and two maximum flue gas temperatures of 1800 and 1600 F. Special tube alloys are available for corrosive environments--consult North American.

The recuperator can be mounted either vertically or horizontally, and the steel shell is lined with insulation. Recuperator should not be mounted so the tube bundle can "see" the furnace interior, especially on high temperature furnaces. For long tube life, air preheat should be limited to 1200 F.

TEMPERATURE LIMITATIONS

Flue Gases—

When flue gas temperatures are above 1600 F for -L models or 1800 F for -H models, dilution air must be introduced to cool flue gases upstream of the recuperator for overtemperature protection.

Air Preheat—

During periods of system turndown, combustion air preheat temperature must not exceed 1200 F. Either air must be introduced into the flue gas upstream of the recuperator, or combustion air flow must be increased to limit air preheat to 1200 F.

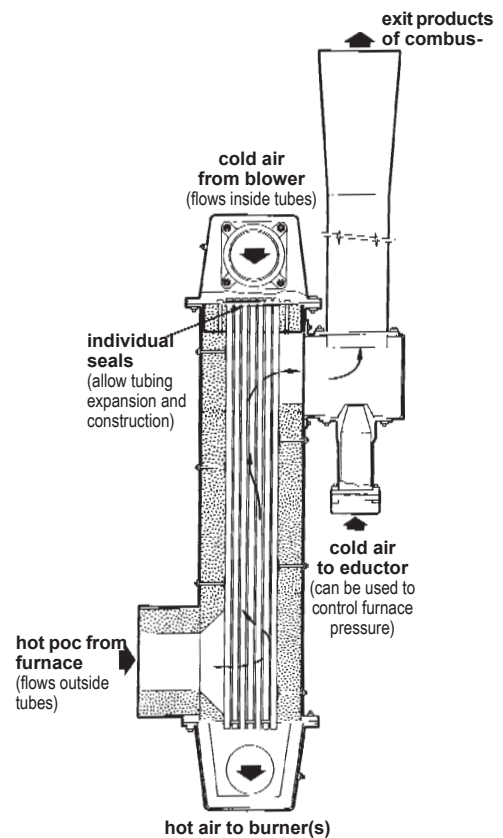
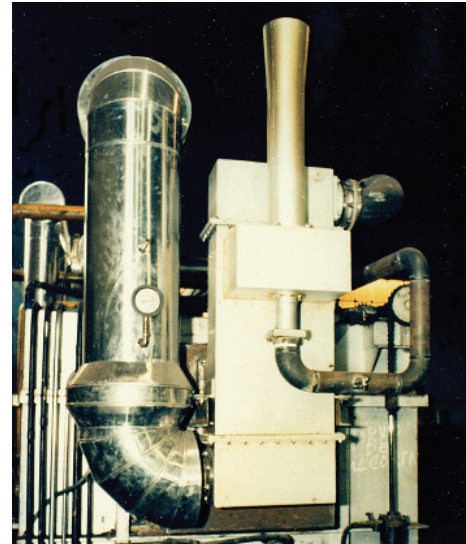

EDUCTOR AIR REQUIREMENTS

Nozzle	Pressure eductor air	Volume % combustion air
"special"	12 osi	100%
"R"	16 osi	90%
"S"	20 osi	80%

8485 OVERALL DIMENSIONS

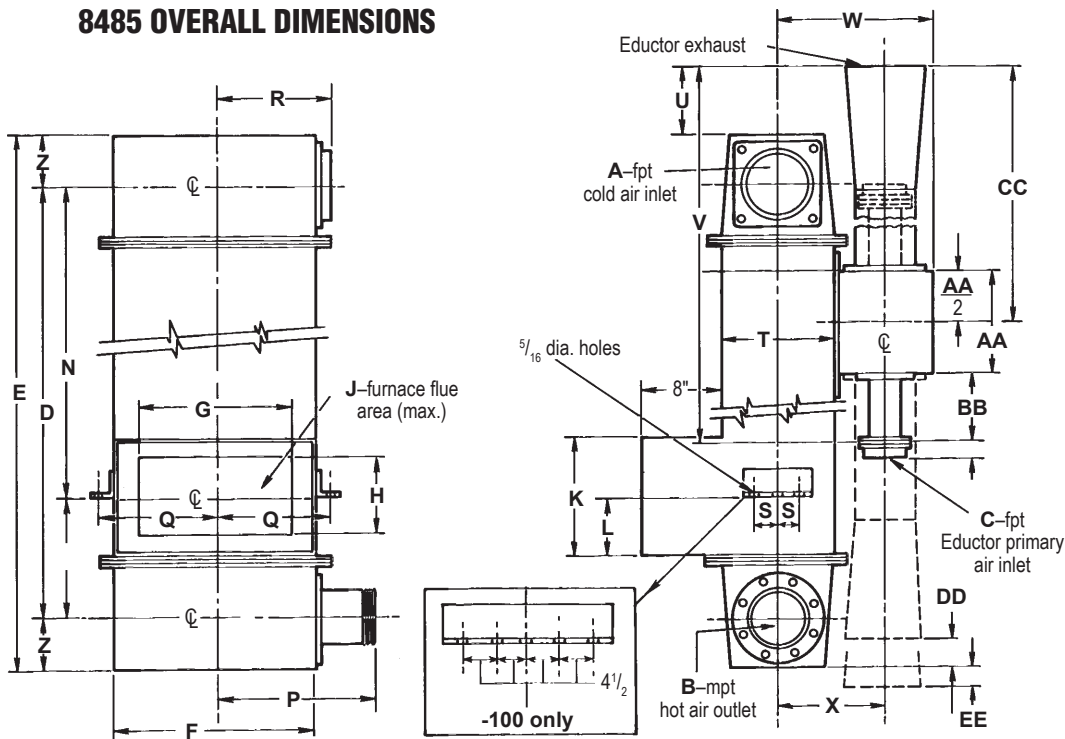

ARRANGEMENTS

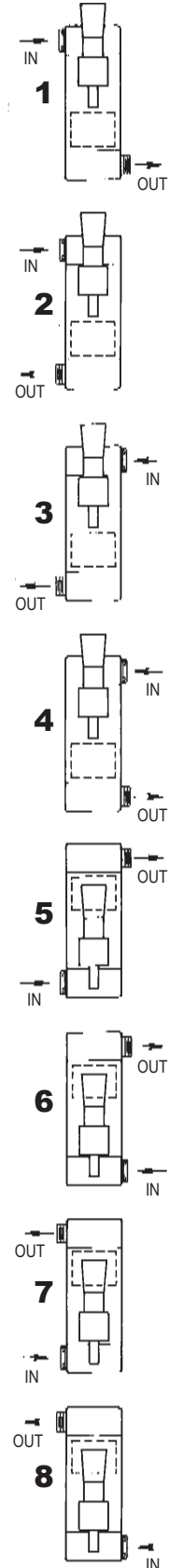

Designation	A	B	C	D	E	F	G	H	J	K	L	M	N	P	Q
8485-4.5-X	2 1/2	2 1/2	1 1/2	4 11/16	46 11/16	10	5 5/8	4 3/4	26 3/4	9	4 1/2	8 1/4	33 1/16	8 1/16	6 3/4
8485-4.5-Y	2 1/2	2 1/2	1 1/2	53 11/16	58 11/16	10	5 5/8	4 3/4	26 3/4	9	4 1/2	8 1/4	55 1/16	8 1/16	6 3/4
8485-7.0-X	3	3	2	43 3/16	49 11/16	12 3/8	8	4 3/4	38	9	4 1/2	9	34 3/16	9 1/4	8 1/16
8485-7.0-Y	3	3	2	55 3/16	61 11/16	12 3/8	8	4 3/4	38	9	4 1/2	9	46 3/16	9 1/4	8 1/16
8485-12-X	4	4	2 1/2	43 3/16	49 11/16	15 1/8	10 3/4	4 3/4	51	9	4 1/2	8 15/16	34 1/16	10 5/8	9 3/16
8485-12-Y	4	4	2 1/2	55 3/16	61 11/16	15 1/8	10 3/4	4 3/4	51	9	4 1/2	8 15/16	46 1/16	10 5/8	9 3/16
8485-20-X	6	6	3	47 1/16	57 3/16	20 3/8	16	8	128	12 1/4	6 1/8	12 3/4	34 11/16	13 1/4	11 3/16
8485-20-Y	6	6	3	59 3/16	69 3/16	20 3/8	16	8	128	12 1/4	6 1/8	12 3/4	46 11/16	13 1/4	11 3/16
8485-32-X	6	6	3	47 1/16	57 3/16	20 3/8	16	8	128	12 1/4	6 1/8	12 3/4	34 11/16	13 1/4	11 3/16
8485-32-Y	6	6	3	59 3/16	69 3/16	20 3/8	16	8	128	12 1/4	6 1/8	12 3/4	46 11/16	13 1/4	11 3/16
8485-60-X	8 †	10	4	52 11/16	67 3/16	26 7/8	22 1/2	8	180	12 1/4	6 1/8	15 3/8	37 7/16	17 15/16	15 1/16
8485-60-Y	8 †	10	4	64 11/16	79 3/16	26 7/8	22 1/2	8	180	12 1/4	6 1/8	15 3/8	49 9/16	17 15/16	15 1/16
8485-100-X	8	10	4 ‡	53 3/16	69 3/16	38 1/2	34 1/2	8	276	12 1/4	6 1/8	15 1/2	37 11/16	27 3/4	21 3/16
8485-100-Y	8	10	4 ‡	65 3/16	81 3/16	38 1/2	34 1/2	8	276	12 1/4	6 1/8	15 1/2	49 11/16	23 3/4	21 3/16

Designation	R	S	T	U	V	W	X	Y	Z	AA	BB	CC	DD	EE	Approx. wt, lb
8485-4.5-X	6 3/16	2 5/16	7 3/8	11 7/16	35 1/8	11 3/16	7 11/16	1 1/16	2 1/2	6 1/4	6	23	12 1/8	-	185
8485-4.5-Y	6 3/16	2 5/16	7 3/8	11 7/16	35 1/8	11 3/16	7 11/16	1 1/16	2 1/2	6 1/4	6	23	24 1/8	-	210
8485-7.0-X	7 3/4	2 5/16	7 1/4	12	35 1/8	11 1/8	7 13/16	1 1/16	3 1/4	6 1/8	6 1/4	25 7/16	10 13/16	-	245
8485-7.0-Y	7 3/4	2 5/16	7 1/4	12	35 1/8	11 1/8	7 13/16	1 1/16	3 1/4	6 1/8	6 1/4	25 7/16	22 13/16	-	275
8485-12-X	9 1/8	2 5/16	8 5/8	21	44 11/16	13 3/8	9 1/4	1 3/16	3 5/16	6 7/8	6 13/16	34 7/16	11 13/16	-	315
8485-12-Y	9 1/8	2 5/16	8 5/8	21	44 11/16	13 3/8	9 1/4	1 3/16	3 5/16	6 7/8	6 13/16	34 7/16	13 13/16	-	360
8485-20-X	12	2 5/16	8 5/8	21 3/16	50 15/16	15 1/8	10 1/4	1 9/16	4 7/8	9 3/4	6 3/16	39 7/8	-	1 1/8	460
8485-20-Y	12	2 5/16	8 5/8	21 3/16	50 15/16	15 1/8	10 1/4	1 9/16	4 7/8	9 3/4	6 3/16	39 7/8	10 7/8	-	525
8485-32-X	12	3 1/2	11 1/4	28 3/16	57 15/16	16 3/4	11 9/16	1 9/16	4 7/8	9 3/4	6 3/16	46 7/8	-	8 3/8	550
8485-32-Y	12	3 1/2	11 1/4	28 3/16	57 15/16	16 3/4	11 9/16	1 9/16	4 7/8	9 3/4	6 3/16	46 7/8	3 5/8	-	650
8485-60-X	17 15/16	4 1/4	16 7/8	41 1/8	78	22 7/16	15 7/8	1 9/16	7 1/4	11 9/16	6 7/16	65 3/4	-	23 1/4	700
8485-60-Y	17 15/16	4 1/4	16 7/8	41 1/8	78	22 7/16	15 7/8	1 9/16	7 1/4	11 9/16	6 7/16	65 3/4	-	11 1/4	1000
8485-100-X	23 3/4	-	20 5/8	42 1/16	76 1/2	23 3/16	17 3/8	1 9/16	8	9 3/4	7 1/4	64 3/8	-	20	1500
8485-100-Y	23 3/4	-	20 5/8	42 1/16	76 1/2	23 3/16	17 3/8	1 9/16	8	9 3/4	7 1/4	64 3/8	-	8	2200

† mpt ‡ 2 Eductor inlets.

"How to order" instructions are on OES 8000.

DIMENSIONS SHOWN ARE SUBJECT TO CHANGE. PLEASE OBTAIN CERTIFIED PRINTS FROM FIVES NORTH AMERICAN COMBUSTION, INC. IF SPACE LIMITATIONS OR OTHER CONSIDERATIONS MAKE EXACT DIMENSION(S) CRITICAL.

WARNING: Situations dangerous to personnel and property may exist with the operation and maintenance of any combustion equipment. The presence of fuels, oxidants, hot and cold combustion products, hot surfaces, electrical power in control and ignition circuits, etc. are inherent with any combustion application. Parts of this product may exceed 160F in operation and present a contact hazard. Fives North American urges compliance with National Safety Standards and insurance Underwriters recommendations, and care in operation.

Fives North American Combustion, Inc., 4455 East 71st Street, Cleveland, OH 44105 USA, Phone 216.271.6000
Fax 216.641.7852 email: fna.sales@fivesgroup.com • www.fivesgroup.com/fivesna